



## Design of Automated Image Injecting and Painting Robot

S.Kalaimagal

II Year M.E Embedded Systems Technologies Sri Ramakrishna Engineering College Coimbatore, India

A.Arun Raja

Assistant Professor M.E Embedded Systems Technologies Sri Ramakrishna Engineering College Coimbatore, India

### ABSTRACT

*Wall painting is a repetitive, exhausting and hazardous process which makes it an ideal case for automation. There is a strong need for a mobile robot that can move to paint interior walls of residential buildings. In this paper, the conceptual design of an autonomous wall painting robot is described consisting of an arm that scans the walls. IR sensors are attached to the mobile platform and used to maintain a certain distance from the facing wall and to avoid collision with side walls. When settled on adjusted distance from the wall, the controller starts the painting process autonomously. The design objective is to satisfy the criteria of simplicity, low weight, low cost.*

**KEYWORDS :** Construction, Wall Painting Robot, spray Painting, Building Automation, Safety

### I. INTRODUCTION

Construction paint robots are still in use today but are of inferior quality and safety to the latest electronic offerings. The newest robots are accurate and deliver results with uniform film builds and exact thicknesses. Reducing the complexity of painting systems is an important aspect of product development. Originally paint robots were large and expensive, but today the prices of the robots have come down. The selection of today's paint robot is much greater, varying in size and payload to allow many configurations for painting items of all sizes. The prices vary as well as the new robot market becomes more competitive and the used market continues to expand. Building and construction is one of the major industries around the world. In this fast moving life construction industry is also growing rapidly. But the labors in the construction industry are not sufficient. This insufficient labor in the construction industry is because of the difficulty in the work. This automatic wall painting robot is not designed using complicated components. This robot is simple and portable. The robot is designed using few steels, conveyor shaft, spray gun and a controller unit to control the entire operation of the robot. This robot is compact because of high speed and pressure capabilities they have.

### II. OVERALL STRUCTURE SCHEME

The construction of the automatic wall painting robot consists of two main parts. They are

#### 1. Mobile Platform

- Frame Stand
- Stepper Motor
- Spur Gears
- Control Unit

#### 2. Spray gun mount

- IR sensor
- Flow control valve
- Spray gun

#### I. Frame Stand

The frame stand is the steel welded in such a way that it can carry the whole equipment. The steels are welded strongly in welding laboratory with an idea to carry the entire robot with the control unit, Stepper motor in the mobile platform and the IR sensor, solenoid valve and spray gun in the roller shaft. Limit switches are attached to the frame stand in order to move the robot in the direction specified. The Spur gears are controlled by the Stepper motor rotation which is controlled by the ARM microcontroller.

### II. Stepper Motor

A *stepper motor* (or *step motor*) is a brushless DC electric motor that divides a full rotation into a number of equal steps. The motor's position can then be commanded to move and hold at one of these steps without any feedback sensor (an open-loop controller), as long as the motor is carefully sized to the application. It is an electromechanical device which converts electrical pulses into discrete mechanical movements. The shaft or spindle of a *stepper motor* rotates in discrete *step* increments when electrical command pulses are applied to it in the proper sequence.

### III. Spur Gear Mechanism

**Spur gears** are the most common type of gears. They have straight teeth, and are mounted on parallel shafts. Spur gears have high power transmission efficiency, compact and easy to install, offer constant velocity ratio, highly reliable, can be used to transmit large amount of power (of the order of 50,000 kW). Spur gears have a wide range of applications. They are used in Metal cutting machines, Power plant, Marine engines, Mechanical clocks and watches, Fuel pumps, Washing Machines, etc.

### IV. Control Unit

The microcontroller used in the controller unit is LPC2148 ARM microcontroller. The microcontroller unit is used to control the stepper motors and the movement of spray gun fitted on the conveyor belt. Microcontroller unit is provided with the 5V signal and as soon as the supply is ON, LCD gets initialized. The controller sets to setting mode and the moving and painting distance are given as input to the microcontroller. The microcontroller controls the rotation of DC motor based on the distances given in order to control conveyor belt movement. When IR receiver receives the signal, the conveyor belt moves and the spray gun goes to ON condition and if the conveyor belt stops, the spray gun goes to OFF condition. It contains relays for the control of forward and backward movement of the stepper motors. When the microcontroller receives the signals from IR sensor, it will be taking a decision to operate the machine. This pulse signal received from IR sensor circuit when there is any object.

### V. Liquid Crystal Display

A liquid crystal display (LCD) is a flat panel display, electronic visual display, or video display that uses the light modulating properties of liquid crystals (LCs). LCs do not emit light directly. They are used in a wide range of applications, including computer monitors, television, instrument panels, aircraft cockpit displays, signage, etc. They are common in consumer devices such as video players, gaming devices, clocks, watches, calculators, and telephones. LCDs have replaced cathode ray tube (CRT) displays in most applications. They are available in

a wider range of screen sizes than CRT and plasma displays, and since they do not use phosphors, they cannot suffer image burn-in. LCDs are, however, susceptible to persistence. A 16x2 LCD is connected to the microcontroller.

**VI. IR sensor**

IR sensor is used for this project. IR (Infrared) is the typical light source being used in the sensor for robot to detect opaque object. IR Sensor (IR Receiver and IR Emitter) the basic principle of IR sensor is based on an IR emitter and an IR receiver. IR emitter will emit infrared continuously when power is supplied to it. On the other hand, the IR receiver will be connected and perform the task of a voltage divider. IR receiver can be imagined as a transistor with its base current determined by the intensity of IR light received.

**III. WORKING PRINCIPLE**

Block diagram in Fig. 1 shows the working of this robot. Four limit switches are given as inputs to the ARM LPC2148. Two limit switch inputs are given for the vertical movements and another two limit switch inputs for the horizontal movements. When the spray gun touches the limit switch it will stop at that place and moves in another direction. L293D is a current amplifier and simply termed Motor Driver. The inputs of L293D are En1, En2, In1, In2, In3 and In4. L293D is a typical Motor driver or Motor Driver IC which allows DC motor to drive on either direction. L293D is a 16-pin IC which can control a set of two DC motors simultaneously in any direction. It works on the concept of H-bridge. H-bridge is a circuit which allows the voltage to be flown in either direction.

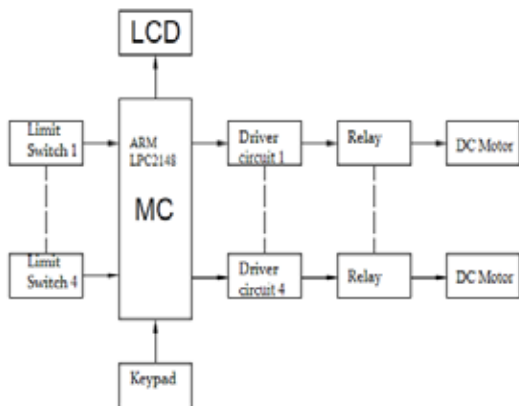

**Fig. 1 Block Diagram**

**III. EXPERIMENTAL SETUP**

Overall mechanical setup of this paper is shown in the Fig. 2. Two stepper motor is used in this setup for driving vertical and horizontal movements of painting robot.



**Fig. 2 Overall mechanical setup**

Gear box setup shown in the Fig. 3 works on the principle of spur gear mechanism.

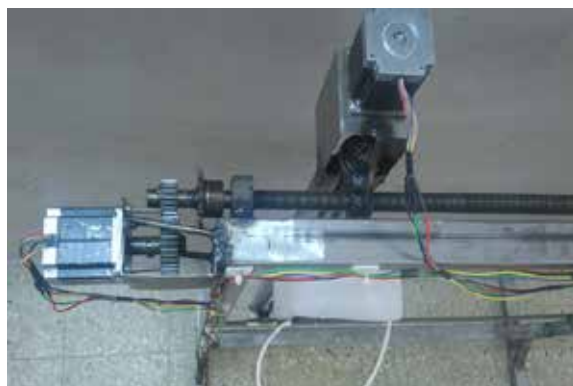

**Fig. 3 Gear box setup**

The 12V signal from the battery is given to the power supply unit where it gets regulated to 5V. The 5V signal is given to the microcontroller unit. Once the supply is ON, LCD gets initialized. The microcontroller sets to setting mode and the moving and painting distance is given as input to microcontroller. Fig. 4 shows the controller unit arrangement of this painting robot. When the IR receiver receives the signal, the conveyor belt moves and spray gun goes to ON condition. If the conveyor belt stops then spray gun goes to OFF condition.

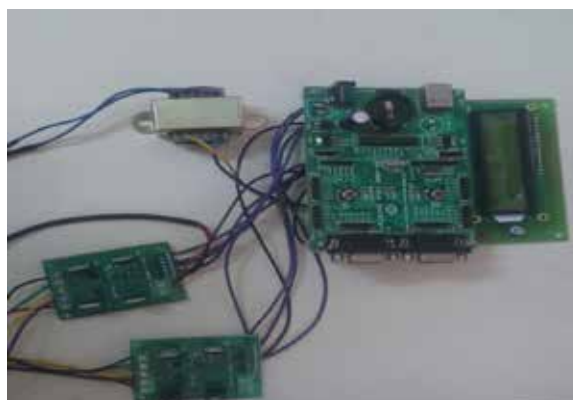

**Fig. 4 Controller unit**

**IV. EXPERIMENTAL RESULT**

After LCD initialisation MOVING DISTANCE is displayed in the LCD display and the distance is given as input by programming. The movement of the robot will be in one direction along the wall. The robot continues to paint till the wall ends by having painting distance.



**Fig. 5 Moving distance input**

**V. CONCLUSION**

The robot eliminates the hazards caused due to the painting chemicals to the human painters such as eye and respiratory system problems. The nature of painting procedure that requires repeated work and hand rising makes it boring, time and effort consuming. The robot is cost effective, reduces work force for human workers. Painting robot has many advantages such as: uniform spraying, high efficiency and path diversity, which becomes the most competitive high quality spray equipment.

**REFERENCES**

- [1] Thomas F, Ros L. Revisiting trilateration for robot localization. *IEEE Transactions on robotics*, 2005, 21: 93-99. | [2] Vadakkepat P, Miin O, Peng X, et al. Fuzzy behavior based control of mobile robots. *IEEE Trans. fuzzy syst.* 2004, 12: 559-567. | [3] Wang L L, Wang H R, Xia J Z, et al. Stable adaptive controller for stabilized platform with parallel-series structure. *Journal of Central South University (Science and Technology)*, 2013, 44: 115-124. | [4] Gao Z, Xiao J Z, Wang H R, et al. Dynamics Analysis on a 3-DOF Rotational Platform with Serial-Parallel Structure. *China Mechanical Engineering*, 2012, 23: 18-25. | [5] Yu Y Y, Wang Y L. Structure design and kinematics analysis of 5-Rcutting robot. *Mechanical engineering and automation*, 2011, 5: 150-154. | [6] Chen Z Q, Liang X H, Lin Y K, et al. Structural design and optimization of 6 axes serial robot. *Machine tool and hydraulics.China*,2013,41:97-101.