



SOLAR ENERGY MEASUREMENT SYSTEM

Naveen Virmanini	Department of Mechanical Engineering, IIMT College of Engineering, Greater Noida, U.P., India
Pankaj Singh	Department of Mechanical Engineering, IIMT College of Engineering, Greater Noida, U.P., India
Prakhar Kumar	Department of Mechanical Engineering, IIMT College of Engineering, Greater Noida, U.P., India
Prashant Bhati	Department of Mechanical Engineering, IIMT College of Engineering, Greater Noida, U.P., India
Rinku Gupta	Department of Mechanical Engineering, IIMT College of Engineering, Greater Noida, U.P., India
Rohit Gupta	Department of Mechanical Engineering, IIMT College of Engineering, Greater Noida, U.P., India

ABSTRACT

The aim of this proposed work is to measure solar cell parameters through multiple sensor data acquisition. In this project, a solar panel is used that keeps monitoring the sunlight. Here different parameters of the solar panel like light intensity, voltage, current and the temperature are monitored and are sent to a remote PC using a RF 2.4 GHz serial link. Microcontroller used here is from PIC16F8 family.

KEYWORDS : SP-solar panel, PIC-programmable industrial controller, LCD-liquid crystal display and LED-light emitting diode.

1. INTRODUCTION

The solar-energy market is one of the most rapidly expanding renewable energy markets in the United States. Presently we have seen a significant increase in requests for remote monitoring and control equipment for solar-energy applications. Whether you are assessing a site's potential for solar power generation, monitoring performance of existing solar installations, or advanced solar monitoring, reliable and accurate measurements are crucial. They aid in decision making, product development, system maintenance and in many other ways. Common meteorological measurements including wind speed, wind direction, relative humidity, barometric pressure and precipitation, all have their use in solar applications. Of course, solar-radiation measurements are especially important and sensors are available for measuring all aspects of solar radiation.

The main objective of this project is to design a solar energy measurement system for measuring solar cell parameters such as voltage, current, temperature and light intensity through multiple sensors.

The light intensity is monitored using a LDR sensor, voltage by voltage divider principle, current by series resistor and temperature by temperature sensor. All these data are displayed on a 16X2 LCD interfaced to PIC microcontroller and is also sent to a remote PC hyper terminal for display using a 2.4 GHz serial link. The proposed system uses a PIC16F series family microcontroller and a rectified-power supply. In this work, a solar panel is used to keep a track on monitoring the sunlight. In this system, number of sensors are connected to the microcontroller with an 8-channel in-built ADC device for monitoring the parameter of the solar panel like voltage, current, temperature and light intensity. A 16x2 LCD display is connected to the microcontroller for displaying the information. The solar panel is fed to the microcontroller through a potential divider to measure voltage – a small load through which current is measured. The temperature and light intensity is monitored through corresponding sensors. All these parameters are displayed on the 16x2LCD interfaced to the PIC microcontroller.

2. BLOCKDIAGRAM

The light intensity is monitored using an LDR sensor, voltage by voltage divider principle, current by series resistor and temperature by temperature sensor. All these data are displayed on a 16X2 LCD interfaced to PIC microcontroller and is also sent to a remote PC hyper terminal for display using a 2.4 GHz serial link.

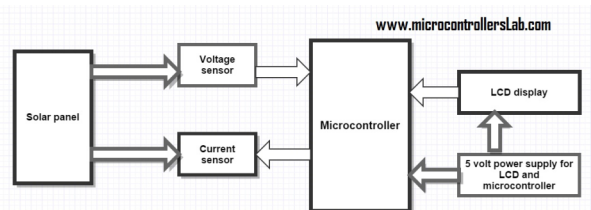

Fig. 1. Block diagram of solar energy measurement system

In the block diagram, voltage sensor and current sensor are used to measure voltage and current flowing to load from solar panel. As we know, solar panels are dc power sources. Liquid crystal display is used to display the value of current, voltage and power of solar panel. 5 volt dc power is used to provide operating voltages to microcontroller and liquid crystal display.

3. CIRCUIT DIAGRAM

Fig 2. Circuit diagram for solar energy measurement system

As shown in Fig 2.Circuit diagram, the voltage divider is used to divide voltage to lower than 5 volt. Because microcontroller cannot

read voltage more than 5 volt. Therefore voltage divider is used to lower voltage less than 5 volt. Polar and nonpolar capacitors are used to remove harmonics and to provide constant voltage to ADC pin of microcontroller. Polar capacitor is used to avoid voltage fluctuation and non-polar capacitor is used to remove harmonics.

We can use LM35 temperature sensor which is calibrated in Celsius over kelvin because in kelvin calibrated sensor there is a requirement of subtract a constant voltage from its output to is easy. The temperature sensor LM35 can be used with single power supply. The temperature range for operating is -55 to +150 Celsius. The LM35 sensor is suitable for remote applications. Operating voltage such sensor is varies from 4 to 30 V. When the intensity of light is increases then the resistance of LDR is decreases. This is also known as photoconductor.

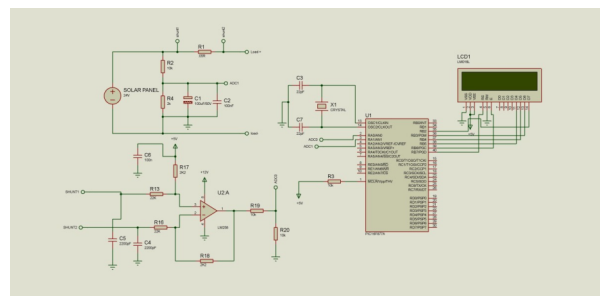
A LDR(light dependent resistor) is made of a high resistance semiconductor when the falling light on the device is of enough frequency then the photons absorbed by the semiconductor. Thus in resulting free electron conduct electricity thereby resistance is decreases. IV IN4007-The IN4007 is used in rectifier to convert AC to DC. The important factor is that IN4007 have maximum reverse bias voltage capacity.

A shunt resistor of .05 ohm is used in series to load. Voltage drop across shunt resistor used to measure current. Here shunt resistor is used as a transducers which converts current into voltage, as microcontroller cannot read current directly. Output of shunt resistor is fed to difference amplifier. Difference amplifier step up the voltage. In case of very low current, small voltage will appear across shunt resistor and microcontroller cannot read voltage less than its resolution. Followings are the main parts: Current sensor, voltage sensor, PIC16F877A microcontroller, LCD display, Power supply

I] AC VOLTAGE MEASUREMENT UNIT:

According to voltage sensor formula, for solar panel of 24 volt values of voltage divider resistors are R2 = 10K and R4 = 2K. The reason I have used voltage divider because the maximum input voltage to Analog to digital converter can never be greater than 5 volt. But I calculated these resistor values according to 4 volt to increase accuracy of measurement and to insure protection of ADC in case of greater voltage fluctuation.

II] Current sensor circuit diagram:

Below is a circuit diagram of current measurement circuit. I have used difference amplifier to amplify voltage appearing across shunt resistor. Because current value may be too high and too low in different timings and different voltage will generate across shunt resistor. So it is not possible to use voltage divider as we don't know the values of current. A current sensor is a device that detects and converts current to an easily measured output voltage, which is proportional to the current through the measured path.[5],[6] When a current flows through a wire or in a circuit, voltage drop occurs. Also, a magnetic field is generated surrounding the current carrying conductor. Both of these phenomena are made use of in the design of current sensors. Thus, there are two types of current sensing: direct and indirect. Direct sensing is based on Ohm's law, while indirect sensing is based on Faraday's and Ampere's law.

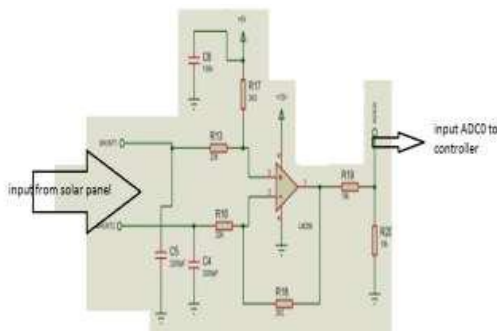

PASSIVE ELEMENT BASED CURRENT SENSING TECHNIQUES: -Sense Resistors -Low value in order to minimize power losses. -Low inductance because of high di/dt.

4. WORKING

The power supply which is =5 v is connected to pin no.11 and 32 of microcontroller and GND is connected to its pin no. 12 and 31. Pin no. 2 of microcontroller is connected to LDR sensor. Pin no. 3 of microcontroller is connected to pin no. 2 of LM35 temperature sensor. Pin no. 4 of microcontroller is connected to voltage sensing circuit, Pin no. 5 of microcontroller is connected to current sensing circuit. Solar power parameter calculator is the device to calculate the intensity, temperature, current and voltage represent them on the LCD screen. [5]

We can use LM35 temperature sensor which is calibrated in Celsius over kelvin because in kelvin calibrated sensor there is a requirement of subtract a constant voltage from its output to is easy. The temperature sensor LM35 can be used with single power supply. The temperature range for operating is -55 to +150 Celsius. The LM35 sensor is suitable for remote applications. Operating voltage such sensor is varies from 4 to 30 V. When the intensity of light is increases then the resistance of LDR is decreases. This is also known as photoconductor. The LDR(light dependent resistor) is made of a high resistance semiconductor when the falling light on the device is of enough frequency then the photons absorbed by the semiconductor.

Thus in resulting free electron conduct electricity thereby resistance is decreases. IV IN4007-The IN4007 is used in rectifier to convert AC to DC.

6. CONCLUSION

In this paper we tried to measure parameters of solar panels such as Voltage, current, power, temperature and intensity of light using PIC16F877A microcontroller. Digital display can be used to display values of these parameters. PIC microcontroller can be used to measure analog values of these sensed parameters and analog to digital to converter which is in built in PIC microcontroller can be used to measure values of these parameters. There are many ways to sense voltage. But in this proposed work we can easily measure voltage of solar panel using voltage divider. Two capacitors connect parallel to voltage measurement resistor to avoid voltage fluctuation and avoid harmonics to go into ADC of PIC microcontroller. Here we have used differential amplifier to amplify voltage appearing across shunt resistor, because current value may be too high and too low in different timings.

7. ACKNOWLEDGMENT

We take this opportunity to express my gratitude to Mr. S. V. DHOLE while writing the article on "REVIEW OF SOLAR ENERGY MEASUREMENT SYSTEM". We are very grateful to Dr. Prof. A. A. Shinde, HOD Electronics Department for giving us an expert guidance and encouragement. We also take this opportunity to express our sincere gratitude to all the staff of Electronics Dept. for their support and cooperation, without which, the task would have been much more daunting. We would also like to express our thanks and respects to our parents as well as to other family members and friends whose encouragement was main source of our energy behind this work.

REFERENCES

- [1] Duy C. Huynh, Member, IEEE, and Matthew W. Dunnigan, "Development and Comparison of an Improved Incremental Conductance Algorithm for Tracking the MPP of a Solar PV Panel" IEEE TRANSACTIONS ON SUSTAINABLE ENERGY, VOL. 7, NO. 4, OCTOBER 2016.
- [2] Pooja Sharma, Siddhartha P. Duttgupta, and Vivek Agarwal, Senior Member, IEEE "A Novel Approach for Maximum Power Tracking From Curved Thin-Film Solar Photovoltaic Arrays Under Changing Environmental Conditions" IEEE TRANSACTIONS ON INDUSTRY APPLICATIONS, VOL. 50, NO. 6, NOVEMBER/DECEMBER 2014.
- [3] "Solar radiation measurement" written by Tom Stoffel & Steve Wilcox at Aug. 20004.
- [4] "How a solar cell converts solar Energy to Electricity" written by Turner, Gillian in 2006. microcontrollerslab.com
- [5] N. Femia, G. Petrone, G. Spagnuolo, and M. Vitelli, "Optimization of perturb and observe maximum power point tracking method," IEEE Trans. Power Electron., vol. 20, no. 4, pp. 963–973, Jul. 2005.

- [7] N. Kasa, T. Iida, and L. Chen, "Flyback inverter controlled by sensor less current MPPT for photovoltaic power system," *IEEE Trans. Ind. Electron.*, vol. 52, no. 4, pp. 1145–1152, Aug. 2005.
- [8] H. Shao, C. Y. Tsui, and W. H. Ki, "The design of a micro power management system for applications using photovoltaic cells with the maximum output power control," *IEEE Trans. Very Large Scale Integration. (VLSI) System.*, vol. 17, no. 8, pp. 1138–1142, Aug. 2009.
- [9] P. Favrat, P. Deval, and M. J. Declercq, "A high-efficiency CMOS voltage doubler," *IEEE J. Solid-State Circuits*, vol. 33, no. 3, pp. 410–416, Mar. 1998.
- [10] T. Tanzawa and S. Atsumi, "Optimization of word-line booster circuits for low-voltage flash memories," *IEEE J. Solid-State Circuits*, vol. 34, no. 8, pp. 1091–1098, Aug. 1999.