



## A Boost Converter with Voltage Multiplier for Photovoltaic Applications

### KEYWORDS

Boost flyback converter, high step up, photovoltaic system, voltage multiplier module

Lakshmy Suresh

EEE Department, Maharaja Institute of Technology,  
Coimbatore-641407, India .

Ms.Anitha.R

AP, EEE Department, Maharaja Institute of Technology,  
Coimbatore-641407, India .

**ABSTRACT** A high step up converter is proposed for a front end photo voltaic system. Through a voltage multiplier module, an asymmetrical interleaved high step-up converter obtains high step-up gain without operating at an extreme duty ratio. The voltage multiplier module is composed of a conventional boost converter and coupled inductors. An extra conventional boost converter is integrated in to the first phase to achieve a considerably higher voltage conversion ratio. The two-phase configuration not only reduces the current stress through each power switch, but also constrains the input current ripple, which decreases the conduction losses of metal-oxide-semiconductor field-effect transistors (MOSFETs). In addition, the proposed converter functions as an active clamp circuit, which alleviates large voltage spikes across the power switches. Thus the low-voltage-rated MOSFETs can be adopted for reduction of conduction losses and cost. Efficiency improves because the energy stored in leakage inductances is recycled to the output terminal. Finally, the prototype circuit with a 40V input voltage, 380V output, and 1000W output power is operated to verify its performance. The highest efficiency is 96.8%.

### Introduction

Among renewable energy systems, photovoltaic systems are expected to play an important role in future energy production. Such systems transform light energy into electrical energy, and convert low voltage into high voltage via a step-up converter, which can convert energy into electricity using a grid-by-grid inverter or store energy into a battery set. The high step-up converter performs importantly among the system because the system requires a sufficiently high step-up conversion

Renewable sources of energy are increasingly valued worldwide because of energy shortage and environmental contamination. Renewable energy systems generate low voltage output, thus high step up dc to dc converters are widely employed in many renewable energy applications including fuel cells, wind power and photovoltaic systems.

A high step-up converter is proposed for a frontend photovoltaic system. Through a voltage multiplier module, an asymmetrical interleaved high step-up converter obtains high step up gain without operating at an extreme duty ratio. The voltage multiplier module is composed of a conventional boost converter and coupled inductors. An extra conventional boost converter is integrated into the first phase to achieve a considerably higher voltage conversion ratio. The two-phase configuration not only reduces the current stress through each power switch, but also constrains the input current ripple, which decreases the conduction losses of metal-oxide-semiconductor field effect transistors.

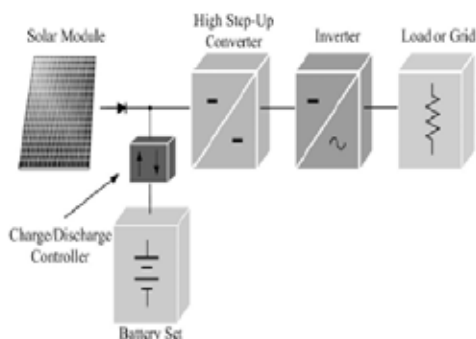

Fig 1. Typical Photovoltaic system

### A. Advantages of Photovoltaic system.

Photovoltaic (PV) systems provide green, renewable power by exploiting solar energy. We can use photovoltaic (PV) panels as an alternative energy source in place of electricity generated from conventional fossil fuels. Consequently, the more we use PV panels (or other renewable energy technologies) to cover for our energy needs, the more we help reduce our impact to the environment by reducing CO<sub>2</sub> emissions into the atmosphere

Output capacitor is larger than input capacitor that sup Photovoltaic (PV) panels constitute a reliable, industrially matured, green technology for the exploitation of solar energy. Photovoltaic (PV) companies give valuable warranties for PV panels in terms of both PV panel life span (years of PV life) and PV panels' efficiency levels across time. PV panels can last up to 25 years or more, some with a maximum efficiency loss of 18% only, even after 20 years of operation.

With respect to operating costs and maintenance costs, Photovoltaic (PV) panels, unlike other renewable energy technologies, require minimum operating or maintenance costs; just performing some regular cleaning of the panel surface is adequate to keep them operating at highest efficiency levels as stated by manufacturers' specs.

### II. PROPOSED SYSTEM

In this paper, an asymmetrical interleaved high step-up converter that combines the advantages of the aforementioned converters is proposed, which combined the advantages of both. In the voltage multiplier module of the proposed converter, the turns ratio of coupled inductors can be designed to extend voltage gain, and a voltage-lift capacitor offers an extra voltage conversion ratio. In this paper a high step-up converter is proposed for a frontend photovoltaic system. Through a voltage multiplier module, an asymmetrical interleaved high step-up converter obtains high step up gain without operating at an extreme duty ratio. The voltage multiplier module is composed of a conventional boost converter and coupled inductors. An extra conventional boost converter is integrated into the first phase to achieve a considerably higher voltage conversion ratio. The two-phase configuration not only reduces the current stress through each power switch, but also constrains the input current ripple, which decreases the conduction losses of metal-oxide-semiconductor field effect transistor

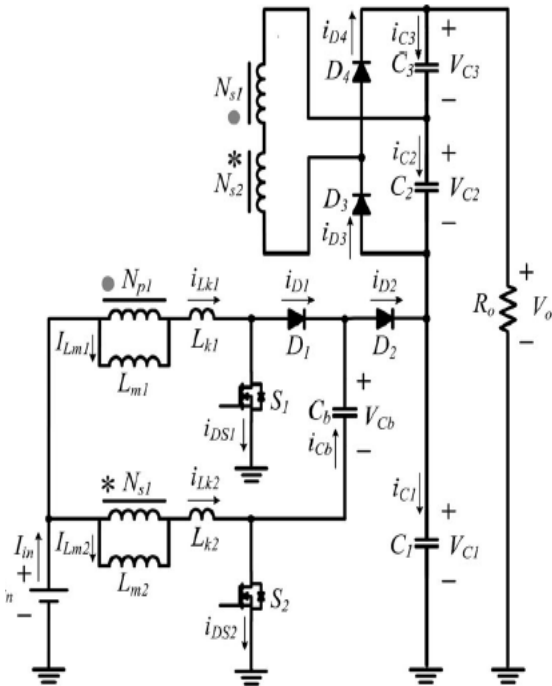

Fig 3. Equivalent circuit of proposed converter

**PROPOSED CONTROL METHOD**

The proposed method adopts continuous mode of operation. So the stress on the switching device will be less and hence efficiency will be more. MOSFET in the flyback converter is controlled by the sinusoidal pulse width modulation. In sinusoidal pulse width modulation, carrier signal is a triangular wave and reference signal is a sine wave. By comparing the reference signal with the carrier wave gating pulses are generated. The main advantage of PWM(Pulse Width Modulation) is that the power loss in the switching device is very less.

**A . OPERATING PRINCIPLE**

The switching period can be subdivided in to six modes of operation. The modes 1-3 are same as modes 4-6. So the first three modes are explained here. To make the circuit operation simpler, some assumptions are made the transformer leakage inductances are negligible

The magnetizing inductances Lm1 and Lm2 are identical

The phase shift between two switches are 180°

Mode 1: In mode 1, S1 is ON and S2 is ON. All of the diodes are reverse biased. Magnetising inductors Lm1 and Lm2 as well as leakage inductors Lk1 and Lk2 are linearly charged by the input voltage source Vin1.

Mode 2: The switch S2 is switched OFF, thereby turning ON diodes D2 and D4. The energy that magnetizing inductor Lm2 has stored is transferred to the secondary side charging the output filter capacitor C3

Mode 3: Diode D2 automatically switches OFF because the total energy of leakage inductor Lk2 has been completely released to the output filter capacitor C1.

**OPEN LOOP SIMULATION**

The system proposed can be simulated with MATLAB software. The components and various parameters used for simulation is as shown in table 1.

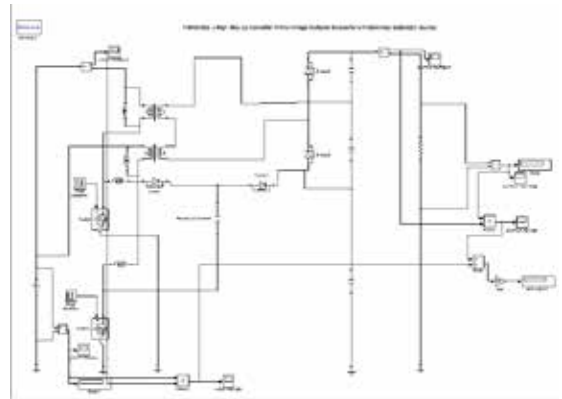

Fig 6. Openloop simulink model

TABLE 1: simulation parameters

ITEMS	VALUES
V <sub>in</sub>	40V Dc
V <sub>o</sub>	400V
I <sub>o</sub>	0.4826A
Lk1 and Lk2	1.6µH
c1	470µf
c2,c3	220µf
magnetising inductance $l_{m1}=l_{m2}$	133µh
output resistance r <sub>o</sub>	100Ω

The input and output voltage and current waveforms for open loop simulations are as shown figure below. An input voltage of 40V is applied. The output voltage and current are obtained as 400V and 2.5A. So output power is 800w.

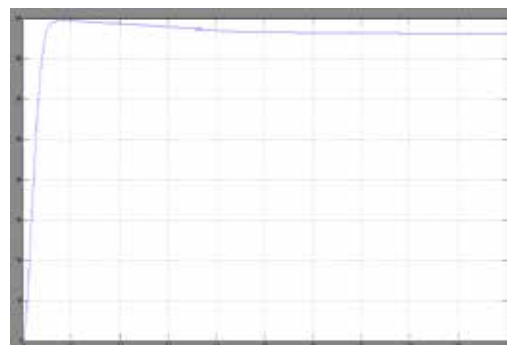

Fig 5. Output voltage waveform

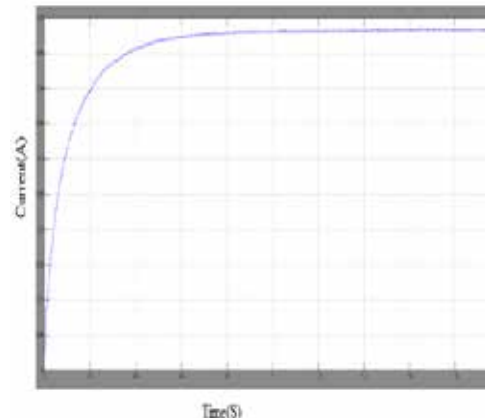

Fig 6. Output current waveform

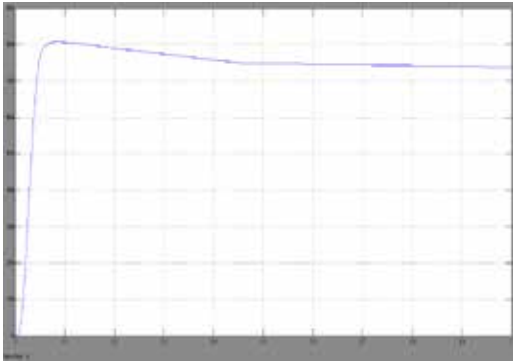

Fig 7. Output power

**V CLOSED LOOP SIMULATION**

As a modification closed loop simulation is done using a PI controller . The simulink model is as shown in figure 7 below. Parameter values and input voltage is same as in open loop simulation.

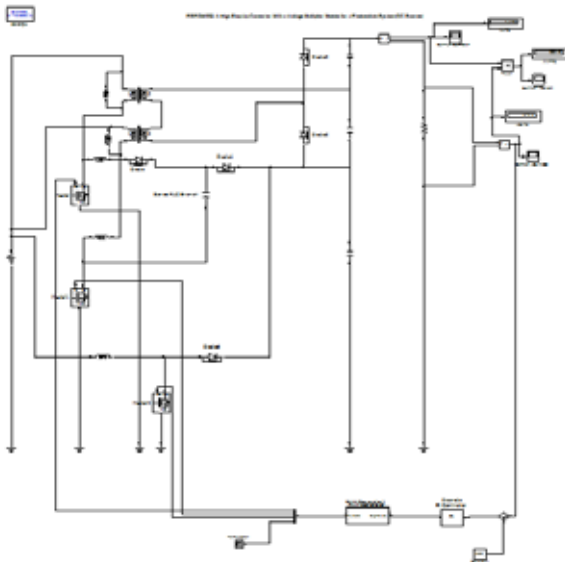

Fig 7. Closed loop simulink model

An input voltage of 40V dc is given. Output voltage and current are obtained as 650V and 2.7A. So the output power is W. ie, by doing closed loop simulation , output power is almost doubled. Ripple content in the voltage is same as that obtained with the open loop simulation. The output voltage and current waveforms of the closed loop simulation are as shown in figure 8 below.

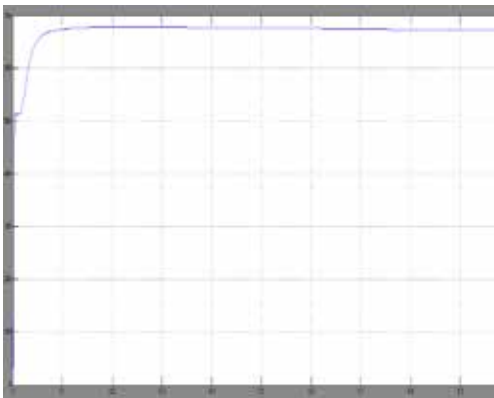

Fig 8. Output voltage waveform

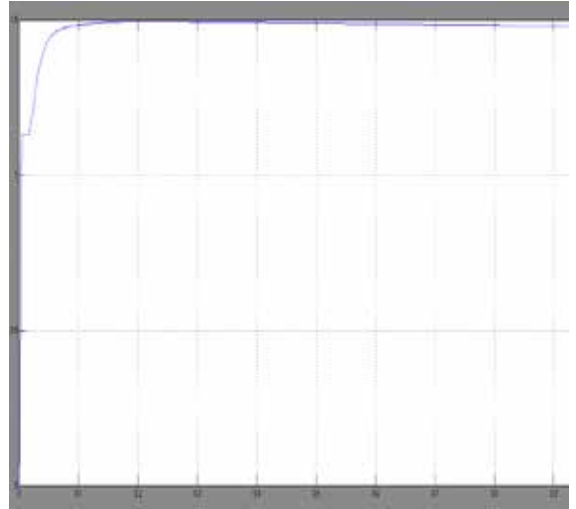

Fig 9. Output current waveform

**VI. COMPARISON OF OPENLOOP AND CLOSED LOOP SIMULATION**

The results of open loop and closed loop simulations are compared and as shown in the table 2 below.

**TABLE 2: COMPARISON OF SIMULATION RESULTS**

	OPEN LOOP	CLOSED LOOP
Input voltage	40V dc	40V dc
Input current	2.5A	2.5A
Output voltage	400V dc	650V dc
Output current	2.5A	2.7A
Output power	800W	994W
Efficiency	96.58%	98.28%

**VII. ADVANTAGES OF THE CONVERTER**

- It has low input current ripple and low conduction losses,making it suitable for high power applications
- Converter achieves high voltage gain
- Leakage energy is recycled and sent to the output terminals,and alleviates large voltage spikes on the main switch
- Low cost and high efficiency

**VII. CONCLUSION**

In this work, a Boost converter with voltage multiplier module for photovoltaic systems is presented. The proposed converter provides high voltage gain with low cost and high efficiency. This can be used for high power applications with lesser component count . In open loop simulation we are getting an output power of 800W . This can be increased to 994W by doing the closed loop simulation.Hence the proposed converter is suitable for photovoltaic applications that need high step up high power energy conversion.

**REFERENCE**

- [1] "Electromagnetic compatibility(EMC),"Part3,International Standard IEC61000-3-2, 2001. || [2] Y.-C. Chuang,Y.-L.Ke, H.-S. Chuang, andC.-C. He, "Single-stage powerfactor-correction circuit with flyback converter to drive LEDs for lighting applications," in Proc. IEEE Ind. Appl. Soc. Annu. Meeting, 2010, pp. 1–9. || [3] R. Redl and L. Balogh, "Design considerations for single-stage isolated power-factor-corrected power supplies with fast regulation of the output voltage," in Proc. IEEE Appl. Power Electron. Conf., 1995, vol. 1, pp. 454–458. || [4] L. Huber and M. M. Jovanovic, "Single-stage single-switch input-currentshaping technique with reduced switching loss," IEEE Trans. Power Electron., vol. 15, no. 4, pp. 681–687, Jul. 2000. || [5] K.-H. Liu and Y.-L. Lin, "Current waveform distortion in power converters," in Proc. IEEE Power Electron. Spec. Conf., 1989, pp. 825–829. || [6] D. Gacio, J. M. Alonso, A. J. Calleja, J. Garcia, and M. R. Secades, "A universal-input single-stage high-power-factor power supply for HBLEDs based on integrated buck-flyback converter," IEEE Trans. Ind. Electron., vol. 58, no. 2, pp. 589–599, Feb. 2011. |