



A Technological Literature Survey on STATCOM utilising Cascaded Multilevel Converter (H Bridge)

KEYWORDS

Cascaded multilevel inverter (H-bridge), Static synchronous compensator (STATCOM), Flexible ac transmission system (FACTS), Pulse width modulation (PWM), Gate turn off thyristor (GTO), Emitter turn off thyristor (ETO), Total harmonic distortion (THD).

RAKESHKUMAR B. SHAH

Lecturer, Electrical Engineering Department, R. C. Technical Institute, Sola, Ahmedabad. (GUJARAT)

Prof. SANJAY R. VYAS

Associate Professor, Electrical Engineering Department, LDRP Institute of Technology and Research, Gandhinagar. (GUJARAT)

ABSTRACT *Though extensive literature exists on the cascaded multilevel inverter, while now STATCOM are showing increasing popularity in recent years for industrial application. In the last 42 years conventional thyristor-based power electronics has been increasingly used for the compensation and control of electric power transmission systems. This technology, represented by line-commutated converters for HVDC transmission, and by thyristor-switched and controlled capacitors and reactors for reactive shunt and series compensation of ac transmission lines, has contributed significantly to the practical realization of today's highly efficient interconnected transmission networks. This Literature Survey is dedicated to a comprehensive study of static synchronous compensator (STATCOM) systems utilizing cascaded-multilevel inverters.*

INTRODUCTION: -

Among flexible AC transmission system (FACTS) controllers, the STATCOM have shown feasibility in terms of cost effectiveness in a wide range of problem-solving abilities from transmission to distribution levels. A cascade multilevel inverter is a power electronic device built to synthesize a desired AC voltage from several levels of DC voltages. A cascade multilevel inverter can be implemented using only a single DC power source and capacitors. To operate a cascade multilevel using a single DC source, it is proposed to use capacitors as the DC sources. A standard cascade multilevel inverter requires $2s+1$ DC sources for $2s+1$ level. To be able to operate in a high-voltage application, a large number of DC capacitors are utilized in a cascaded multilevel inverter-based STATCOM. To obtain a low distortion output voltage or a nearly sinusoidal output waveform, a triggering signal should be generated to control the switching frequency of each power semiconductor switch.

Jose Rodriguez, Jih-Sheng Lai, and Fang Zheng Peng "Multilevel Inverters: A Survey of Topologies, Control and Applications" performed in August 2010. In this paper, the multilevel inverter technology has emerged recently as a very important alternative in the area of high-power medium-voltage energy control. This paper presents the most important topologies like diode-clamped inverter, capacitor clamped and cascaded multi-cell with separate dc sources. Emerging topologies like asymmetric hybrid cells and soft-switched multilevel inverters are also discussed. This paper also presents control and modulation methods for these converters like multilevel sinusoidal pulse width modulation, multilevel selective harmonic elimination and space vector modulation. These converters are applied in laminators, mills, conveyors, pumps, fans, blowers, compressors and unified power flow controllers. Multilevel inverters include an array of power semiconductors and capacitor voltage sources, the output of which generate voltages with stepped waveforms. Multilevel inverters can generate output voltages with low distortion and low dv/dt . They draw input current with very low distortion. They generate smaller common mode voltage. They can operate with a lower switching frequency. Multilevel inverters

are extensively used in high power applications with medium voltage levels. This paper presents multilevel technology, considering well established and emerging topologies as well as their modulation and control techniques. Inverter topologies are diode clamped, flying capacitor and cascaded multicell inverters. Modulation strategies are sinusoidal PWM (SPWM), multilevel SPWM, space vector PWM, selective harmonic elimination, space vector control (SVC). Today more and more commercial products are based on the multilevel inverter structure. Worldwide research and development of multilevel inverter related technologies are occurring [1].

Laszlo Gyugyi "Application Characteristics of Converter-Based FACTS Controllers" performed on 2000 presents the switching-converter based approach to flexible AC Transmission Systems from an application viewpoint. It is shown that this approach, apart from providing superior performance characteristics when applied for shunt and series reactive compensation, also offers modular expandability and functional convertibility for comprehensive real and reactive power flow, as well as voltage control, for a single transmission line or for a multi-line network, making system-wide optimization and maximum asset utilization possible. To meet the transmission challenges, the flexibility of present transmission systems needs to be increased under the prevailing economic and environmental constraints which necessitate the full utilization of existing and new transmission assets. The switching converter based technology, using power semiconductors with gate turn off capability, offers very good functional capabilities for real and reactive power flow, voltage profile control, to achieve comprehensive and precise line loading management and high degree of system stability. Functional arrangements of STATCOM, SSSC, UPFC, and IPFC have been discussed. The converter based FACTS controllers have superior operating and performance characteristics, functional convertibility and system operational adaptability and expandability. The converter based FACTS controllers are used to solve the transmission problems and meet the power delivery challenges [2].

F.Z. Peng, J.W.McKeever and D.J.Adams "Cascade Multilevel Inverters for Utility Application" performed on February 2003 presented a cascaded M-level inverter consists of (M-1)/2 H-bridges in which each bridge has its own separate dc sources. The new inverter: (1) can generate almost sinusoidal waveform voltage while only switching one time per fundamental cycle, (2) can eliminate transformers of multipulse-inverters used in conventional utility interfaces and static var compensators, and (3) makes possible direct parallel or series connection to medium and high voltage power systems without any transformers. In other words, the cascade inverter is much more efficient and suitable for utility applications than traditional multipulse and pulse width modulation (PWM) inverters. Cascade multilevel inverter used for utility interface of renewable energy, voltage regulation, var compensation and harmonic filtering in power systems. The cascade inverter has less component count and is more suitable for utility applications than other multilevel inverters. Three phase star/delta connected 11-level cascade inverter for utility applications and waveforms are shown. Cascade inverters can be used for (a) Utility interface of renewable energy sources (b) Voltage regulation and phase shifting (c) Reactive power control and compensation (d) Harmonic filtering. The inverter can generate leading or lagging reactive power as commanded. The cascade inverter is suitable for FACTS applications including var/harmonic compensation, series compensation, phase shifting, and voltage balancing. Each DC capacitor voltage can be self maintained and independently controlled without additional DC sources. This cascade inverter topology can be adapted to fuel cell and photovoltaic utility interfaces where the sources are naturally isolated DC sources. Cascade multilevel inverter can eliminate the bulky transformers, generate almost sinusoidal waveform, has fast dynamic response. It is modular and simple in structure. It provides lower cost, higher performance, less EMI, higher efficiency than traditional PWM inverter [3].

Leon M. Tolbert, Fang Zheng Peng and Thomas G. Habetler "Multilevel Converters for Large Electric Drives" performed in January/February 1999. They presented transformer less multilevel converters as an application for high-power and/or high-voltage electric motor drives. Multilevel converters: 1) can generate near sinusoidal voltages with only fundamental frequency switching; 2) have almost no electromagnetic interference or common-mode voltage; 3) are suitable for large volt ampere-rated motor drives and high voltages. The cascade inverter is a natural fit for large automotive all-electric drives because it uses several levels of dc sources, which would be available from batteries or fuel cells. The back-to-back diode-clamped converter is ideal where a source of ac voltage is available, such as in a hybrid electric vehicle. Motor insulation failure become a problem with some ASDs because increased switching speed of power semiconductor devices causes steep voltage wave front to appear at the motor terminals. dV/dt can be high enough to induce corona discharge between the winding layers. Multilevel inverters overcome these problems. A multilevel cascade inverter with separate DC sources and multilevel diode clamped back to back converter is proposed for use in large electric drives. These converters have low output voltage THD, high efficiency and power factor. They are suitable for large volt amp rated and/or high voltage motor drives. No EMI problem or common mode voltage/current problem exists. No charge unbalance problem in either rectifier mode or inverter mode. Simulation and experimental results show the superiority of these two converters over two-level

pulse width-modulation-based drives [4].

PheeKkuan Jin, Mohamed S.A.Dahidah and Christian Klumpner "Nine-level SHE-PWM VSC Based STATCOM for VAR Compensation" performed on 29 Nov.-1 Dec. 2010 presented a nine-level selective harmonics elimination pulse width modulation (SHE-PWM) cascaded voltage source converter based STATCOM system. The structure allows direct connection to the grid without the need of any step-up transformers. The converter is controlled with the SHE-PWM technique which provides an elimination to lower order harmonics to improve output waveforms and furthermore, allowing the use of smaller filters. Multilevel converter based STATCOM technology is slowly replacing advanced static var compensation (ASVC) due to its good harmonic performance. Multilevel converter eliminates the need of bulky transformers or high power devices. Near sinusoidal voltage output can be synthesized with low switching frequencies. Three multilevel technologies: diode clamp, flying capacitor and cascaded converter. In this paper SHE-PWM nine level converter based STATCOM which is connected at the point of common coupling (PCC) of 240V, 50Hz, AC system. The proposed STATCOM eliminates the need of coupling transformers and large size filters, also have better THD. The cascaded SHE-PWM multilevel converter is able to operate in a self regulating manner where its capacitors will be recharged with the controlled flow of active power from the grid. Proposed STATCOM fixes the capacitors at fixed voltage and varies the modulation index to control the voltage. Sufficient phase shift between V_t and V_c in order to channel some active power from the system to the STATCOM to recharge the capacitors and to sustain its voltage at a reference value. The proposed STATCOM delivers high quality waveforms with simple structure and efficient control methodology with low switching losses. Output waveforms are free from low order harmonics and having good THD values. The DC capacitor voltages can be self maintained at reference voltage without any coupling of other dc sources. These features are desirable and applicable for any (FACT) application. The operation and the performance of the STATCOM for reactive power (VAR) compensation are validated by simulation studies using SIMULINK/MATLAB software which confirm the theoretical predictions [5].

GezaJoos, Xiaogang Huang and Boon-TeckOoi "Direct-Coupled Multilevel Cascaded Series Var Compensators" performed in September/October 1998. Series capacitive var compensation has been used for many years to enhance transmission capacity and dynamic security of transmission systems, in the form of fixed or switched capacitors. To increase the flexibility and improve the dynamic response of var compensation schemes, forced commutated converter structures have been adapted for var compensation. Series Var compensators based on force-commutated static power converters are proving to be a viable alternative to shunt compensators as a means of enhancing power transmission and distribution capability. Most of the structures used for shunt compensation can be transposed to series compensation. The static power converters are coupled to the system through transformers. Use of transformer increases the cost and reduces the overall efficiency of compensator. This paper proposes a converter structure, based on a multilevel cascade of single-phase converters, which can be coupled to the transmission system without transformers. Alternate approach series compensation based on the removal of the transformer and the direct insertion of active voltage sources in series with the transmission line. The line provides the in-

ductance needed to interface the voltage source inverters of the compensator with the power system. Single phase inverters are used. Higher voltage levels are satisfied by multilevel structure of series connected single phase converters fed from independent self controlled and isolated dc capacitor buses. Advantages of the proposed series compensator include low injected voltage harmonic distortion and fast response to changes in the compensation level [6].

John N. Chiasson, Leon M. Tolbert, Keith J. McKenzie and Zhong Du "Control of a Multilevel Converter Using Resultant Theory" performed on May 2003. In this work, a method is given to compute the switching angles in a multilevel converter to produce the required fundamental voltage while at the same time cancel out specified higher order harmonics. Complete analysis is given for a seven level converter (three dc sources). For a range of modulation index, the switching angles can be chosen to produce the desired fundamental voltage V_1 , while making the fifth and seventh harmonics identically zero. The approach gives the exact range of modulation index for which solutions exist and gives all possible solutions. A full solution to the problem of eliminating the fifth and seventh harmonics in a seven level multilevel inverter has been given. Resultant theory was used for each m when a solution existed and when it did not. For each value of m the solution set that minimized the 11th and 13th harmonics was chosen [7].

Jih-Sheng Lai, Senior Member, IEEE and Fang Zheng Peng, Member, IEEE "Multilevel Converters-A New Breed of Power Converters" performed in May/June 1996. In this paper, multilevel voltage source converters are emerging as a new breed of power converter options for high-power application. The multilevel voltage source converters typically synthesize the staircase voltage wave from several levels of dc capacitor voltages. One of the major limitations of the multilevel converters is the voltage unbalance between different levels. The techniques to balance the voltage between different levels normally involve voltage clamping or capacitor charge control. This paper presents three multilevel voltage source converters: 1) diode-clamp 2) flying capacitors 3) cascaded inverters with separate dc sources. Multilevel starts from three levels. In the first two types excessive clamping diodes and large amount of storage capacitors are needed. In case of cascaded inverters the least number of components are required among all multilevel converters. Modular circuit layout and packaging is possible. Soft switching can be used. It needs separate DC sources for real power conversion. All three converters can be used as static var generator. Using multilevel converters not only solves harmonics and EMI problems but also avoids high frequency switching dv/dt induced motor failures [8].

Jingsheng Liao, Keith Corzine and Mehdi Ferdowsi "A new control method for single dc source H-bridge multilevel converters using phase shift modulation" performed in 2008. Multilevel converters have gained popularity in high power applications due to their low switch voltage stress and modularity. Cascade H-bridge converters are a promising breed of multilevel converters, which require several independent dc sources. This paper proposes a new control method applicable to single dc source cascaded H-bridge multilevel inverters to improve their capacitor voltage regulation. The proposed method has a wide voltage regulation range over the capacitors replacing the dc sources in the H-bridge converter cells. This method is more robust and has less computational burden. The main

inverter switches at the fundamental frequency and the auxiliary inverter switches at the PWM frequency. Voltage regulation of the capacitor in the auxiliary converter is a challenging task. Capacitor voltage regulation is achieved by adjusting the active and reactive power that the main converter injects to the load. If α is chosen exactly 18 degrees, then the main converter injects only active power. By shifting the voltage waveform synthesized by the main converter, one could inject some reactive power also, which can be used to charge or discharge the capacitor. Phase shift modulation is used to find the required phase shift. One can regulate the voltage of the capacitor by regulating $\Delta \alpha$ (delta α). Regulation of the capacitor voltage is achieved without deteriorating the total harmonic distortion [9].

Bin Zhang, Alex Q. Huang, Yunfeng Liu and Stanley Atcity "Performance of the new generation Emitter Turn off (ETO) Thyristor" performed in 2002. The emitter turn off (ETO) is a GTO-MOSFET hybrid high power device that can achieve unity turn off gain condition. A new generation of ETO rated at 4500V and 4000Amps has been developed. The improvements are made in the area of manufacturability, functionality and performance. 4000A snubberless turn off capability and low conduction loss are achieved in the new ETO using novel circuits and housing design. This paper presents design, characteristics and performance of the new ETO. ETO is a novel family of high power devices that is suitable for high power and high frequency applications. ETO consists of the emitter switch (Low voltage MOSFETs) in series with a GTO. ETO achieves the unity turn off gain through the emitter switch. Recently, a new generation of the ETO, Gen-3 ETO has been developed. It has 91mm punch through GTO for low conduction loss and low switching loss. New circuit and housing designs are applied to the Gen-3 ETO to achieve high current snubberless turn off, high reliability and high manufacturability. It has turned off 4000A without a snubber. It has advantages of high power rating, low conduction loss, fast switching speed, 4000A snubberless turn off capability, suitable for parallel and series operation, simple interface, suitable for mass production. It is a promising candidate for megawatt application power conversion applications. It is currently being applied to high power STATCOM application [10].

Chang Qian, Mariesa L. Crow "A Cascaded Converter-Based STATCOM with Energy Storage" performed on 2002. Authors said that due to the advantages for high power applications, multi-level converters have been introduced to Flexible AC Transmission Systems to enhance power transmission system operation. Although several multilevel STATCOM topologies have been proposed to verify the high performance of multi-level converters used in reactive power compensation, they are not capable of controlling active power flow. To make multilevel converters more flexible and effective for active power flow control, energy storage systems are incorporated into a cascaded converter based Statcom, such as flywheels and batteries to implement both active and reactive power flow control. Separate D.C. sources are suitable for various energy storage devices such as fuel cells, batteries and fly wheels. Advantages are fewest components are used, modularity of packaging, does not have a capacitor voltage balancing problem with BESS. A multilevel StatCom/ BESS is more versatile and flexible than a conventional StatCom because it can control both active and reactive power, charge batteries by absorbing active power, rated higher because of multilevel topology, effective in power

oscillation damping, support the system voltage during and after a disturbance. The objective of control strategy is to enhance the power transmission operation by injecting or absorbing both active and reactive power to or from the grid [11].

Dr. Jagdish Kumar, "Direct voltage control in distribution system using CMLI based STATCOM". The transfer functions obtained using system identification technique has been used for the determination of controllers' parameters for load bus voltage and capacitor charge balancing using Ziegler-Nichols technique. For fast voltage regulation of power system, there are three different types of STATCOM a) PWM b) Multipulse and c) multilevel. Multilevel inverter produces the desired output voltage by synthesis of several levels of input dc voltages. System identification is a technique/process for determination of proper model of dynamic system under study by using its input output data set. Input output data sets are obtained from time domain simulation or performing experiment on an actual physical system itself. After identification of suitable system models, appropriate control systems can be designed for power system bus voltage regulation and capacitor voltage balance. For validation and performance evaluation digital simulations have been carried out using MATLAB/SIMULINK under different load variations. By comparing simulation, the load voltage control and dc capacitor voltage regulation performance of the CMLI STATCOM have been found satisfactory [12].

Wanki Min, Joonki Min and Jaeho Choi "Control of STATCOM using Cascade Multilevel Inverter for High Power Application" performed in July 1999. This paper proposes the novel control scheme of a static synchronous compensator (STATCOM) with cascade multilevel inverter which employs H-bridge inverter (HBI). The STATCOM system is modeled using the D-Q transform which calculates the instantaneous reactive power. This model is used to design a control strategy based on the control of the phase angle of the fundamental switching pattern. This switching method produces the staircase type waveform in cascade multilevel inverter. The selective harmonic elimination allows keeping the total harmonic distortion low in the output voltage of inverter. The switching pattern is a programmed switching pattern stored in an EPROM. A rotated switching scheme of fundamental frequency is switched to be on and off equally each device and applied to control the DC voltage balancing. As a result, it makes the DC voltage of STATCOM balance and the control response fast to the step change of reactive power. STATCOMs based on multilevel VSI have been widely studied due to its capability of eliminating the zig-zag transformer. There are three different system configurations in multilevel VSI based STATCOM category. A) Diode clamped converter configuration B) Flying capacitor converter configuration C) Cascading converter configuration. In A and B very large numbers of clamping diodes or flying capacitors are used. But C has the advantage of using small numbers of diodes and capacitors. Packaging is very easy due to its modular structure. It is constructed by cascading several voltage sources H-bridge inverter. A seven level three phase based on Cascade voltage source H-bridge inverter configuration is shown. When the inverter output voltage is higher than the ac system voltage, vars are generated. When the inverter output voltage is lower than the ac system voltage, vars are absorbed. When the inverter output voltage is equal to the ac system voltage reactive power exchange is zero. All dc capacitors are equally charged and discharged per one half cycle. The amount of reactive power generated or absorbed is dependent on the difference of am-

plitude between the source voltage and output voltage of cascade multilevel inverter. This STATCOM is also suited for high power application such as FACTS [13].

Manoj Yadav, Harish Kumar and Perminder Balyan "Cascaded Multilevel Inverter based on STATCOM" presented in 2014. Authors said that STATCOM have shown feasibility in terms of cost effectiveness in a wide range of problem solving abilities from transmission to distribution levels. A cascade multilevel inverter is a power electronic device built to synthesize a desired AC voltage from several levels of DC voltages. A method is presented in which cascade multilevel inverter can be implemented using only a single DC power source and capacitors. Use capacitors as the DC sources. A standard cascade multilevel inverter requires "s" DC sources for $2s + 1$ level. To operate in a high voltage application, a large numbers of DC capacitors are used in a cascaded multilevel inverter-based STATCOM. To obtain a low distortion output voltage or a nearly sinusoidal output waveform, a triggering signal should be generated to control the switching frequency of each power semiconductor switch. To control the reactive power, this system is modelled using the ABC transform which calculates the instantaneous reactive power. This model is used to calculate the instantaneous reactive power and design a control scheme. The proposed control system is superior and model is precise.

There are three different system configurations in multilevel VSI based STATCOM category.

A) Diode clamped converter configuration

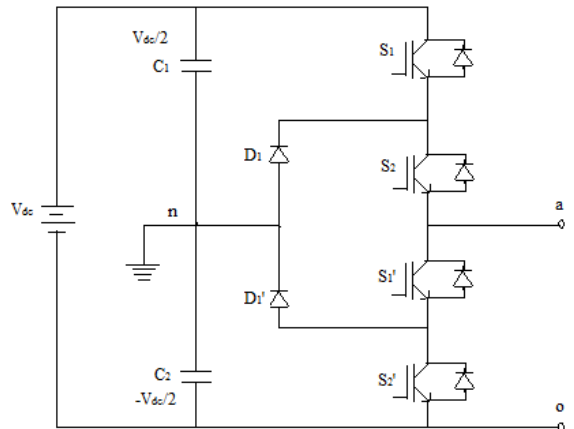

Fig: - 1 Three Level Diode Clamped inverter

B) Flying capacitor converter configuration

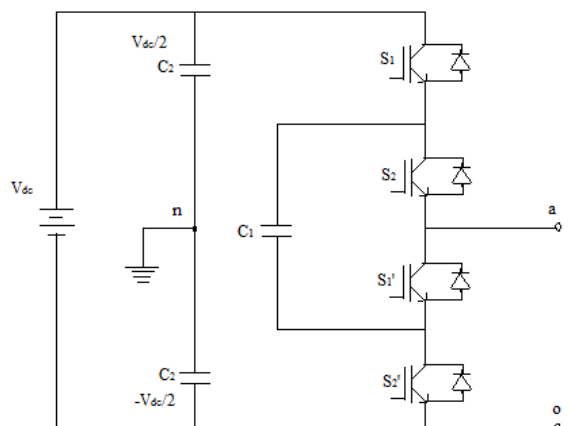

Fig: - 2 Three Level Capacitor Clamped inverter

C) Cascading converter configuration

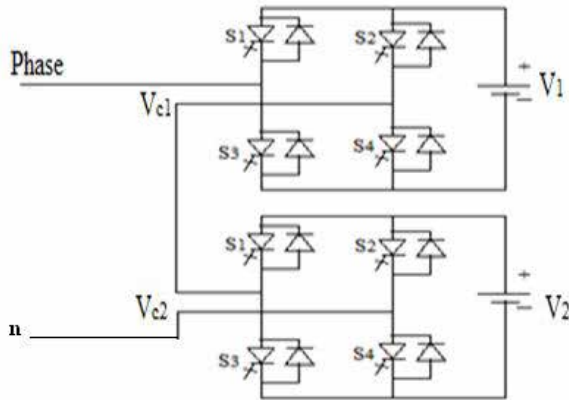

Fig: - 3 Three Level Cascaded inverter

It is hard to connect a single power semiconductor switch directly to medium voltage grids (2.3, 3.3, 4.16, 6.9 KV). So a new family of multilevel inverters has emerged as the solution for working with higher voltage levels. Flexibility of electric power transmission system (FACTS) means "The ability to accommodate changes in the electric transmission system or operating conditions." "A power electronic based system and other static equipment that provide control of one or more AC transmission system parameters to enhance controllability and increase power transfer capability." STATCOM is the first power converter based shunt connected controller. When the terminal voltage of VSC is higher than the ac system voltage, STATCOM generates reactive current/vars are generated. When the terminal voltage of VSC is lower than the ac system voltage, STATCOM absorbs reactive power. Response time of STATCOM is shorter due to fast switching times provided by IGBTs. 11-level three phase STATCOM based on cascaded H-bridge inverter is shown. When the inverter output voltage is higher than the ac system voltage, vars are generated. When the inverter output voltage is lower than the ac system, voltage vars are absorbed. When the inverter output voltage is equal to the ac system voltage reactive power exchange is zero. STATCOM has fewer numbers of devices. VSI is extremely fast in response to reactive power change [14].

Soumya K., "Performance Evaluation of Adjustable Speed Drives using Multilevel Inverter based STATCOM". Adjustable speed drives (ASD) employing induction motors are widely used in the industries such as fans, compressors, pumps etc. They are energy efficient. They inject high harmonic content in to current drawn from the AC system. STATCOM is used for compensation of such loads. STATCOM is a good harmonic filter. Cascaded multilevel converter based STATCOM (CMC-STATCOM) used for applications in both transmission and distribution system. Reactive power control strategy based on the d-q co-ordinate system. Balance of DC bus voltage is a key factor to the stable operation of devices. Hierarchical control method is used to achieve a balance of DC bus voltage. Ever growing use of power electronic based systems has increased the harmonics problem. These devices inject undesirable harmonics into the supply system as well as the neighbouring loads. Low voltage loads can also introduce harmonics in the power network. Cascaded multilevel H-bridge structure is used as converter topology of STATCOM. ASD use power electronic devices, which inject harmonics into the

connected system. High harmonic content in current and voltage. Harmonic currents result in excessive heating in rotating machines. Power Quality problems in distribution system include poor power factor, poor voltage regulation and harmonics. STATCOM can be designed to eliminate all lower order harmonics. This paper gives application of STATCOM for reducing total harmonic distortion in supply current. Control logic is developed to produce an output current which when injected in to the AC lines stops harmonic migration to the power source. No need for the source to supply reactive current. It can operate for lagging/leading/unity power factor loads and provide reactive compensation in both lag/lead Vars [15].

G. Sundar, S. Ramareddy "Digital Simulation of Multilevel Inverter based STATCOM". This paper deals with simulation of STATCOM with the aid of multilevel VSI circuit. Harmonics in STATCOM due to voltage ripple are reduced. Size of inductor and DC capacitor are reduced. STATCOM has fewer numbers of devices. VSI is extremely fast in response to reactive power change. A flexible AC transmission system incorporating power electronic based or other static controllers provide better power flow control and enhanced dynamic stability by control of one or more ac transmission system parameters (voltage, phase angle and impedance). STATCOM is modelled power flow analysis. Continuous and quick control of capacitive or inductive reactive power is provided by STATCOM. Its output voltage is a waveform composed of pulses that approaches a sinusoidal wave. STATCOM is basically DC-AC voltage source converter with an energy storage unit like DC capacitor. STATCOM can be controlled to draw either capacitive or inductive current from the line. Amount and type (capacitive or inductive) of reactive power exchange between the STATCOM and the system can be adjusted by controlling the magnitude of STATCOM output voltage with respect to that of system voltage. A slight phase difference between the system voltage and the STATCOM output voltage is always needed to supply a small amount of real power to STATCOM to compensate the component loss so that the DC capacitor voltages can be maintained. Multilevel inverter based STATCOM is modelled and simulated using the blocks of Simulink. This paper proposed multilevel inverter for the reduction of harmonics in the receiving end voltage. Assume single phase circuit model with balanced load. [16]

S.A. Bashi, N.F. Mailah, M.Z. Kadir and K.H. Leong "Generation of Triggering Signals for Multilevel Converter" performed in 2008. Multilevel converter has become attractive in the power industries and it can be applied in many applications especially on improvement of the power quality. This paper presents the generation of triggering signals used to control the cascaded H-bridge multilevel converter. A simulation circuit of three phase five levels cascaded H-bridge multilevel converter is designed and the triggering signals are observed. Elementary concept of multilevel converter to achieve higher power is to use a series of power semiconductor switches with several lower voltage DC sources to perform the power conveyance by synthesizing a staircase voltage waveform. To obtain a low distortion output voltage or a nearly sinusoidal output waveform, triggering signal should be generated to control the switching frequency of each power semiconductor switch. In this paper triggering signal of multilevel converter are designed using the carrier based PWM scheme. PWM provides high power with low harmonics. One of the terminals of each single phase five levels CHB multilevel inverter is connected as star, while the other

terminal of each single phase CHB multilevel converter is connected to a three phase series load. Twelve pulses triggering pulses is designed to trigger 24 IGBTs to obtain the staircase output voltage. PIC 16F877A microcontroller has been used to generate the required twelve PWM triggering signals. Alternative phase opposite disposition (APOD) modulation has been adopted to generate the triggering signals for seven levels CHB. THD voltages of the seven level multilevel converter are slightly lower compared to five level multilevel converter. A simulation of three phase five level CHB multilevel converter has been developed and compared with a seven level multilevel converter. Final outcome is the experimental triggering signals generated by using microcontroller. [18].

SirojSirisukprasert, Zhenxue Xu, Bin Zhang, Jason Lai, and Alex Q. Huang "A High-Frequency 1.5 MVA H-Bridge Building Block for Cascaded Multilevel Converters using Emitter Turn-off Thyristor" performed in 2002. This paper proposes a 1.5 MVA H-bridge building block (HBBB) using the newly developed emitter turn off (ETO) thyristor to demonstrate the superior performance of the ETO. The modular HBBB is intended to be used in high power cascaded multilevel voltage source converters for reactive power compensation applications. Because of their identical layouts, the HBBB are easily manufactured for both the building blocks itself and for the whole system. Whenever the power requirement of the system needs to be changed, the HBBBs are simply added in to or taken away from the system without redesigning the HBBB component ratings. The proposed HBBB can be used to form a cascaded multilevel converter for reactive power compensations such as STATCOM and SSSC. By electrically connecting these identical building blocks, the cascaded multilevel converter topology can be easily implemented. Low inductance, high voltage film capacitors and air core inductors were selected and designed for long term reliability considerations. The air core inductor was designed to avoid saturation under fault conditions. ETO is a new type of MOS controlled thyristor that is suitable in high power converters due to its improved switching performance and simple control. ETO is a voltage controlled power device. It has a built in over current protection function. Multilevel voltage source converter structure can be applied to high voltage electrical systems such as FACTS and custom power system applications. There are three well known multilevel voltage source converters: diode clamped, flying capacitor and cascaded converters. Cascaded converter with separated dc capacitors is the most feasible topology. HBBB which consists of an H-bridge converter and a dc power source is a common part in a high power application using a cascaded converter. At the full load, ETO-based H-bridge converter is capable to operate at the bus voltage of 2 KV and output rms current of 1 KA, power capability is 1.5 MVA. ETOs (main switches S1 to S4) are capable for 4 KA/4.5 KV. ETO has snubberless turn off capability, but a small dv/dt snubber circuit is required to reduce the switching loss and to increase the long term switch reliability. Due to their identical layout, the HBBBs are easily manufactured. Their modularity makes the entire system modular [19].

Wenchao Song and Alex Q. Huang "Control Strategy for Fault-Tolerant Cascaded Multilevel Converter based STATCOM" performed in 2007. Cascaded multilevel converters have been widely used in STATCOM application. Attention was drawn to the issue of reliability because of the high number of power devices. In this paper, the concept of redundancy is applied to improve the reliability of

CMC, a protection scheme to achieve HBBB redundancy in CMC-based STATCOM is proposed. The operating principle and control strategy are introduced and discussed. A 7-level CMC-based STATCOM simulation platform is set up. Recently cascaded multilevel converter (CMC) has become an attractive topology for STATCOM application due to its simple structure and modularity. CMC requires the fewest components compared to all other multilevel converter topologies. The modularized design of H bridge building block (HBBB) makes it much easier to implement the converter with a large number of levels and achieve higher flexibility and reliability. Reliability is essential in high power applications. It is important to maintain normal operation under fault conditions because failed operation of STATCOM could cause tremendous losses for power grid, especially when STATCOM is injecting reactive power to the grid to support the voltage. This paper proposes a fault tolerant control strategy to achieve the N+1 redundancy in a cascaded multilevel converter based STATCOM system. The modularized HBBB is very suitable for Fault-Tolerant designs because of HBBBs in one phase are identical. One HBBB can be added to CMC as a backup to keep the operation even when one of them fails. This is HBBB redundancy. It is achieved when one uses 2N+1 level CMC to implement the STATCOM instead of 2N-1 level CMC. Bypass the HBBB which contains the failed device, so that cascade failure is prevented and normal operation is maintained. By using this redundancy approach, savings in number of the power devices. Five level CMC will be implemented as a seven level CMC. During normal operation, the output voltage waveform will be seven levels instead of five levels. During fault condition the converter must degraded from 7 to 5 levels. To maintain the output to converter, DC bus voltage needs to be charged to higher value. The output voltage waveform quality is improved. It is suitable for any levels CMC topology. Even losing two output levels, the output reactive power still can be maintained by the proper control. Proposed scheme is very suitable for high power application such as STATCOM or SSSC [20].

Y.T.R. Palleswari, B. Kali Prasanna and G. Lakshmi, "Multilevel STATCOM for harmonic reduction". To improve the performance of power system, by reducing harmonics and managing reactive power, new power equipment is required. During the last decade FACTS devices have been implemented. This paper concentrates on harmonic reduction in 2,3 and 5 level diode clamped inverter based STATCOM. Transmission lines when travels over large distances, they suffer with losses. To compensate these voltage losses many FACTS devices are used. If the system voltage is greater than the inverter voltage, then the STATCOM absorbs the reactive power. If the system voltage is less than the inverter voltage, then the STATCOM generates the reactive power. If the system voltage is equal to the inverter voltage, then there is no reactive power compensation. If the load has inductive part, the current waveform lags behind the voltage waveform with certain angle. System power factor is not equal to unity. There is a need of reactive power compensation for the system. After STATCOM compensation the power factor of the system becomes unity as the reactive component is provided by the STATCOM. STATCOM is also helpful to maintain unity power factor load when load is capacitive. Performance of 2, 3 and 5 level DCMLI has been compared. STATCOM can compensate the inductive and capacitive reactive power irrespective if the levels in inverter. Compared to 2 and 3 level inverter, 5 level inverter has reduced harmonic distortion, less dv/dt stress and reduced switching losses [21].

R.H. Baker and L.H. Bannister "Electric power converters" U.S. Patent 3 867 643, Feb.1975". A programmed switching system for converting direct current in to alternating current or some other variable current, or for converting alternating current of one frequency in to alternating current of another frequency. The system employs a number of stages connected in cascade. Each stage includes an electrical energy source or an electrical energy storage unit and switch adopted to bypass the energy source or storage unit, to interconnect the source or storage unit with other electrical energy source or storage units across a load in a programmed fashion, and to reverse the direction of current flow in the load to apply a quasi-sinusoidal voltage across the load. A number of electric energy sources or electric energy storage elements are interconnected in a programmed fashion to cause an alternating current or some other variable current, to flow in a load. Objective of the invention is to provide a novel inverter. A converter in which a number of electric generators or storage elements providing a quasi constant voltage, combined to obtain a time varying output voltage. Numbers of quasi constant voltage sources are combined to obtain an alternating voltage output. Very efficient inverter whose harmonic content is controllable, low impedance output. Obtain a large voltage by combining a numbers of low voltages. A large power output capability. One frequency is converted into another frequency. Voltage converter system can be assembled from multiplicity of similar modules. Great flexibility is provided in the combination of individual devices and the manner in which these devices are combined to provide an output. A seven stage multilevel inverter has been invented [22].

R. D. Hartalkar, A. R. Soman, "Modelling and simulation of multilevel inverter based STATCOM for compensation of reactive power". Authors deal with power factor correction mode and THD. They have represented analytical approach for cascaded H-bridge multilevel STATCOM regulating the voltage in power system during voltage variations. STATCOM generates controllable ac voltage source behind a transformer leakage reactance due to which the reactance voltage difference produces active and reactive power exchange between STATCOM and the power system transmission network. If output voltage of the STATCOM is greater than the system voltage, then current starts flowing from the STATCOM to the system by injecting reactive power in to the system. If the output voltage of the STATCOM is lower than the system voltage, then the current starts flowing towards the converter by absorbing reactive power. In equilibrium position no exchange of reactive power between STATCOM and system. STATCOM helps in dynamic voltage control, power oscillation damping, transient oscillation damping, transient stability, voltage flicker control, active and reactive power flow control. By increasing the levels of the inverter, THD decreases, switching losses are reduced. STATCOM have very bright scope in future [23].

BBG. Tilak, Yarra. Naveen Kumar, Dr. Ch. Sai Babu, K. Durga Syam Prasad, Haritha. Inavolu "Design of multilevel inverter and its application as STATCOM to compensate voltage sags due to faults". Authors said that the application of multilevel inverters along with STATCOM using SPWM (Sinusoidal pulse width modulation) technique improves the operation and utilization of power system. STATCOM injects reactive component in to the power system during large disturbances. This paper deals with 3-phase to ground fault using RL load. 3 and 5 level inverters have been studied during fault condition. STAT-

COM injects reactive power into the network under the fault conditions. Voltage distortion and switching loss is very small. In 5 levels the number of voltage levels increases the output voltage waveform adds more steps. Output current waveform has the lower THD and efficiency is increased. Load current for 5 level inverter are much more sinusoidal and decrease in THD as the frequency increased [24].

Yaopu Li, Cong Wang, Xu Zhao, Kai Zhang "Research of mining STATCOM based on hybrid multilevel H-bridge inverter". Authors presented a new STATCOM system based on H-bridge inverter. It can be used in mine power network. This paper focuses on a generalized structure of multilevel power converter where individual voltage sources are not necessarily the same. The cascade H-bridge consists of two cells, high voltage cell and low voltage cell. The high voltage cell is responsible for voltage lifting, while the low voltage cell is responsible for PWM modulation. If two cells are cascaded with dc voltages in a ratio of 2:1, the single phase output voltage can reach 7 levels. Increasing voltage levels of output waveform can bring up ac current quality, optimize harmonic spectrum and enhance converter efficiency. The hybrid multilevel is characterized by per phase series connection of a high voltage H-bridge converter and a low voltage H-bridge converter. High voltage converter cell 1 with 200V DC-link and a low voltage converter cell 2 with 100V DC-link. Switching frequency of 50Hz and 1 KHz are assigned to high voltage and low voltage converter. Seven level output voltages of -300, -200, -100, 0, 100, 200, and 300 have been obtained. This paper proposed a new PWM control method. The two cascaded H-bridge have different dc voltages. Due to lower cost and more practical operation, this will greatly promote the application of reactive power compensation [25].

CONCLUSION AND FUTURE WORK PLAN

This Literature Survey is dedicated to a comprehensive study of static synchronous compensator (STATCOM) systems utilizing cascaded-multilevel inverters (H-bridge). Reliability is essential in high power applications. Multilevel inverter technology has emerged a very important alternative in the area of high power medium voltage energy control. It can generate almost sinusoidal voltage waveform and eliminate transformers of multi pulse inverter. It is more efficient. It is superior for reactive power and harmonic compensation. A cascade multilevel inverter is a power electronic device built to synthesize a desired AC voltage from several levels of DC voltages. A cascade multilevel inverter can be implemented using only a single DC power source and capacitors. It is used for utility interface of renewable energy, voltage regulation, var compensation and harmonic filtering in power systems. A high frequency 1.5 MVA H-bridge building block for cascaded multilevel converters using Emitter Turn Off thyristor has been explained. Among flexible AC transmission system (FACTS) controllers, the STATCOM have shown feasibility in terms of cost effectiveness in a wide range of problem-solving abilities from transmission to distribution levels. STATCOM can be used as a good harmonic filter. It regulates voltage and improves dynamic stability. It will provide continuous and quick control of capacitive or inductive reactive power. Application of multilevel inverter along with STATCOM using SPWM (Sinusoidal Pulse Width Modulation) technique improves the operation and utilization of power system. STATCOM injects reactive component into the power system during large disturbances.

Future work plan is to come out with a simulation model of STATCOM based cascaded multilevel inverter and analyze its operation. The cascaded seven-level, nine-level, eleven-level, thirteen-level and fifteen level inverters will be used as the studied system and the cascaded fifteen level inverter based STATCOM will be designed according to the simplified model in abc coordinates. The simulation of the STATCOM will be performed in the Simulink environment and the results will be presented and analysed.

REFERENCE

- [1] Jose Rodriguez, Jih-Sheng Lai and Fang Zheng Peng, "Multilevel Inverters: A Survey of Topologies, Controls, and Applications", IEEE Transactions On Industrial Electronics, Vol. 49, No. 4, August 2002. | [2] Laszlo Gyugyi, "Application Characteristics of Converter-Based FACTS Controllers", IEEE Siemens Power Transmission & Distribution, 2000. | [3] F. Z. Peng, J. W. McKeever and D. J. Adams, "Cascade Multilevel Inverters for Utility Applications", IEEE Transactions On Power Electronics, Vol. 17, No. 6, February 2003. | [4] Leon M. Tolbert, Fang Zheng Peng and Thomas G. Habetler, "Multilevel Converters for Large Electric Drives", IEEE Transactions On Industry Applications, Vol. 35, No. 1, January/February 1999. | [5] PheeKuan Jin, Mohamed S.A. Dahidah and Christian Klumpner, "Nine-Level SHE-PWM VSC Based STATCOM for VAR Compensation", IEEE International Conference On Power and Energy, 29 Nov.-1 Dec. 2010. | [6] Geza Joos, Xiaogang Huang and Boon-Teck Ooi, "Direct-Coupled Multilevel Cascaded Series Var Compensators", IEEE Transactions On Industry Applications, Vol. 34, No. 5, September 1998. | [7] John N. Chiasson, Leon M. Tolbert, Keith J. McKenzie and Zhong Du, "Control of a Multilevel Converter Using Resultant Theory", IEEE Transaction On Control System Technology, Vol. 11, No. 3, May 2003. | [8] Jih-Sheng Lai and Fang Zheng Peng, Member IEEE, "Multilevel Converters-A New Breed of Power Converters", IEEE Transaction On Industry Applications, Vol. 32, No. 3, May/June 1996. | [9] Jingsheng Liao, Keith Corzine and Mehdi Ferdowsi Member IEEE, "A New Control Method for Single DC Source Cascaded H-Bridge Multilevel Converters Using Phase-Shift Modulation", IEEE 2008. | [10] Bin Zhang, Alex Q. Huang, Yunfeng Liu and Stanley Atcitty, "Performance of the New Generation Emitter Turn-Off (ETO) Thyristor", IEEE 2002. | [11] Chang Qian, Manisa L. Crow, "A Cascaded Converter-Based Statcom with Energy Storage", IEEE 2002. | [12] Dr. Jagdish Kumar, "Direct Voltage Control in Distribution System using CMLI based STATCOM", International Journal of Electronics Communications and Electrical Engineering", Vol. 2, Issue 10, Oct. 2012. | [13] Wanki Min, Joonki Min and Jaeho Choi, "Control of STATCOM using Cascade Multilevel Inverter for High Power Application", IEEE International Conference on Power Electronics and Drive Systems, Hong Kong, July 1999. | [14] Manoj Yadav, Harish Kumar, Perminder Balyan, "Cascaded Multilevel Inverter based | On STATCOM", International Journal of Advanced Technology in Engineering and | Science, Volume No. 02, Issue No. 08, August 2014. | [15] Soumya K., "Performance Evaluation of Adjustable Speed Drives using Multilevel Inverter based STATCOM", International Journal of Engineering Research and Applications, Vol. 3, Issue 01, 2013 | [16] G. Sundar, S. Ramareddy, Research Scholar, "Digital Simulation of Multilevel Inverter Based STATCOM", Journal of Theoretical and Applied Information Technology, 2009. | [17] Muhammad H. Rashid, "Power Electronics Circuits, Devices, and Applications | (Second Edition)". | [18] S. A. Bashi, N.F. Mailah, M.Z. Kadir and K.H. Leong, "Generation of Triggering Signals for Multilevel Converter", EuroJournals Publishing, Inc. 2008. | [19] Siroj/Siruskuprasert, Zhenxue Xu, Bin Zhang, Jason Lai, and Alex Q. Huang, "A High-Frequency 1.5 MVA H-Bridge Building Block for Cascaded Multilevel Converters | using Emitter Turn-Off Thyristor" IEEE 2002. | [20] Wenchao Song and Alex Q. Huang, "Control Strategy for fault-Tolerant Cascaded | Multilevel Converter based STATCOM", Semiconductor Power Electronics Center, | IEEE 2007. | [21] Y.T.R. Palleswari, B. Kali prasanna and G. Lakshmi, "Multilevel STATCOM for | Harmonic reduction", International Journal of Application or Innovation in Engineering | And Management (IAIEM), Vol. 02, Issue 10, October 2013. | [22] R.H. Baker and L.H. Bannister, "Electric power converters" U.S. Patent 3 867 643, Feb. | 1975. | [23] R. D. Hartalkar and A. R. Soman, "Modeling and simulation of multilevel inverter based | STATCOM for compensation of reactive power", International Journal of Inventions in | Computer Science and Engineering, Vol. 01, Issue 06, July 2014. | [24] B.B.G. TILAK, Yarra. Naveen Kumar, Dr. Ch. Sai Babu, K. Durga Syam Prasad, Haritha. | Inavolu, "Design of multilevel inverter and its application as STATCOM to compensate | voltage sags due to faults", International Journal of Engineering Research and | Development, Vol. 03, Issue 06, September 2012. | [25] Yaopu Li, Cong Wang, Xu Zhao, Kai Zhang, "Research of Mining STATCOM based on | hybrid multilevel H-bridge Inverter", Scientific Research, Energy and Power | Engineering, 2013, 5, 636-641. |