



Embedded Ethernet Microcontroller Prototype for Different Parameter Monitoring and Control

KEYWORDS

Monitor and control, PIC32MX795F512L Ethernet microcontroller

MsYogita P Dhole

M.E Electronis ,Dr.B.A.M.U
Aurangabad

MsVijayshree

M.E Electronis ,Dr.B.A.M.U
Aurangabad

A More

Asso.Prof,Department of Electro
nics,J.N.E.C,Dr.B.A.M.UAurangab
ad-431001, India

ABSTRACT Main aim of this paper is to Monitor and control Industrial parameter from a remote terminal, with the help of PIC32MX795F512L Ethernet microcontroller.

In this system we are monitoring 2 Analog temperature Channel, 1 Humidity sensor channel & 1 optical sensor channel, connected with 8 LED to get high and low indication for each application simultaneously, also we have provided one hooter indicator which will give alarm for certain Low & High Condition.

Control purpose we have used one 1-Analog temp channel by which we run the fan when high indication appears and stop the fan when high condition disappears.

INTRODUCTION

Today, quite often a remote monitoring is necessary in the Industrial Automation System, Server/control room Automation, Home Automation System etc., the engineer at the Central office is capable to monitor the device without going to the site location. The conventional way to control the device and client computer is by using serial port. This connection is limited only to the fixed length. Internet is the biggest place where the information and data swap over. The internet network has been increasing from day to day, and it already installed in many

Office and industrial buildings. It is the big network that has great advantages for the remote monitoring and controlling. As internets are being more and more easily accessible to anyone nearly everywhere in the world today, it has become a preference in embedded microcontroller for remote monitoring and controlling. The combining of an Ethernet controller with the microcontroller has become the hottest choice for the intelligent system today.

Today, Microchip is, one of the microcontroller manufacturers have developed a single chip microcontroller integrated with built-in Ethernet controller, this improvement will make microcontroller easily to be connected with PC through Ethernet network. Until today, Ethernet is the most widely deployed network and are scalable from the simplest to most complex network up to 248 network mode, that why Ethernet is compelling for embedded application because it will enabling a microcontroller to communicate to a ubiquitous data communication network. The Ethernet technology is based on standard IEEE 802.3 that ensure reliability of network connection and data transmission and this will ensure interoperability. Once the system connected to a network, it can be monitor and controlled through internet. While the Ethernet maximum cable length is 100meter, communication over internet removes any previous distance barrier.

In this paper, we want to propose an PIC32MX795F512L embedded Ethernet microcontroller for different parameter monitoring and control remotely. This controller is used to

monitor device at the faraway location.

Here we are monitoring

a. 1-Normal analog temperature Channel, with 2 LED for Certain high, low condition and hooter for giving alarm in certain high condition.

b. 1 - Analog temperature channel with 2 LED for certain high and low condition also it have electrical switch as a control application by witch Fan get on for high indication OFF for normal condition.

c. 1-Analog humidity sensor channel with 2 LED for Certain high and low condition

d. 1 - Analog Optical Sensor with 2 LED for detection or free indication also it will count 0 to 99

Using PIC32MX795F512L Ethernet microcontroller

Architecture

In this system, the microcontroller with internet connectivity is used to monitor and control various parameters over internet network. This design will have a great advantage for the industrial and commercial application such as remote Parameter monitoring and control of industrial parameter, remote monitoring of Server room temperature, remote monitoring of Cold Storage Room Temperature. It will give flexibility to user for monitor and control various parameters through remotely without going to actual site. In our design here, the PIC32MX795F512L microcontroller system will act like a server and host the web page for temperature, humidity, optical sensor monitoring application. This web page can be accessed by user to monitor temperature through the internet network and control electrical Switch. The system proposed is shown in the fig. 1.

In our design here, the PIC32MX795F512L microcontroller system will act like a server and host the web page for various parameter monitoring and control application. This web page can be accessed by user to monitor

The system proposed is shown in the fig.1.

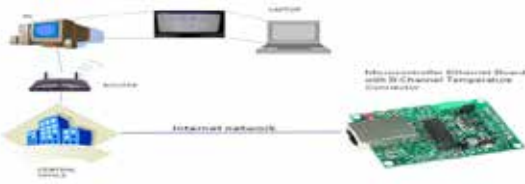

Fig. 1. Proposed System.

HARDWARE IMPLIMENTATION

As per proposed system we required

PIC32MX795F512LMicrocontroller.

- a. One Analog temperature channel with 2 LED and hooter for certain high, low condition.
- b. One Analog humidity sensor channel with 2 LED for Certain high and low condition
- c. One Analog Optical Sensor with 2 LED for detection or free indication also it will count 0 to 99
- d. One Analog temperature channel with 2 LED for certain high and low condition also it have electrical switch as a control application by witch Fan get on for high indication OFF for low condition,

This system implementation we have required

- Sensor
- Processor
- Ethernet controller
- PC
- LED,Fan, Hooter/ Buzzer, Relay, Ethernet cable, Personal computer.

3.1. Sensors:

In this system we are using

- Temperature sensor-LM35
- Humidity Sensor- SY-HS-220
- Trans missive optical sensor

3.1.1. Temperature Sensor:

We use L35 for temperature range -55C to +150C, for higher temperature range we can use PT100 for temperature monitoring up to 800C.sensor input to analog channel is voltage. if sensor output is 4-20mA,then signal conditioning circuit is required between analog channel and sensor output.

3.1.2. Humidity Sensors:

We have used Humidity sensor module SY-HS-220 which can give +- 5 % RH and operating humidity 30-90%RH and having storage capacity of 95% RH

3.1.3. Tran missive Optical Sensor with Phototransistor:

We have used trans missive optical sensor Include an infrared emitter and phototransistor, located face-to-face on the optical axes in a leaded package which blocks visible light. And can be used as Optical switch, Photo interrupter, Counter, Encoder etc.

3.2. Processor & Ethernet Controller:

PIC32MX795F512L is the latest microcontroller manufacture by Microchip. It is a microcontroller with built in Ethernet module. The design of PIC32MX795F512L has meet all of specification require by IEEE 802.3 and completely compatible with 10/100/1000 Base-T network. PIC32 has built in 8-channel analog to digital converter. PIC32MX-

795F512L has meet all of specification require by IEEE 802.3 and completely compatible with 10/100/1000 Base-T network

4. INTERFACING

4.1.Sensor interfacing:

Data collected from actual environment is in analog form but processor will able to process only digital data that's why it is given to Analog to Digital convertor (ADC) before ADC signal conditioning is require in some cases if output of sensor will not having sufficient magnitude to detect by the next step. The output digital data of ADC is given to the processor for processing, where upper and lower thresholdconditions are maintained by using program. Refer fig.2. forSensor interfacing flow chart.

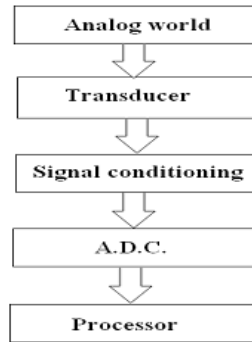

Fig.2. Sensor interfacing flow chart

4.2. Microcontroller to Ethernet jack –RJ45 interfacing:

In order to connect to the internet, a web server requires four main part of the hardware: the media access controller (MAC), network physical interface device (PHY), isolating magnetic and physical jack that connect to the network system.

The four major functional block of this Ethernet module consists:

1. The PHY transceiver module that encode and decode the analog data that is present on the twisted pair interface and send or receive it over the network.
2. The MAC module that implement IEEE 802.3 compliant MAC logic and provide Media Independent Interface Management (MIIM) to control the PHY.
3. An independent, RAM buffer for storing packet that has been received packets that are to be transmitted.
4. An arbiter to control access to the RAM buffer for storing packet that has been receives and packet that is to be transmitted.

Refer figure 3 for Microcontroller to RJ-45 Ethernet Jack block diagram.

The PHY module provides separate output to drive the standard Ethernet indicator.

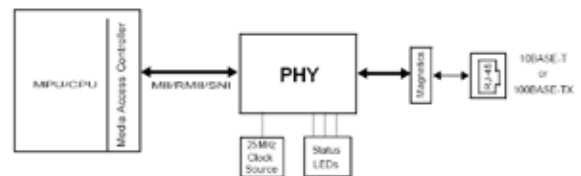

Fig.3.Microcontroller to Ethernet RJ45 jack Diagram

5. SOFTWARE

In this design, software environment are divide into two parts, the first part is C programming language. These language is use to design the microcontroller algorithm to monitor Temperature Channel and control hooter and Electrical Switch. C language has become popular choice for microcontroller programming compare to assembly language. This is because C language is more systematic and easy to arrange compare to assembly language. The second part is the web programming language, it consist of the HTML language. This web programming language is used to design the GUI for the temperature monitor and control application. The communication between the board and the PC client in the system is accomplished by using Transmission Control Protocol/Internet Protocol (TCP/IP).

5.1.Ethernet Communication:

This design used TCP/IP as a communication protocol between the board and the PC client in the network. TCP/IP is a widely used communication protocol for internet. It allows Total location independence and interoperability to any embedded application. In our design for Ethernet communication is based on Microchip TCP/IP stack application for communication between the physical network port and application we want to use. This board application is configured as the web server or HTTP server stores the web pages content in local memory where it capable to serving HTML page to web browser through the network. By this application, we can use this board for status monitoring, remote management, and data retrieval application.

5.2.Web bases application

The web page is used as a GUI which runs on remote client computer to communicate between the user and the board. It allows the web server module to accept data from user through a network. This data can be used to control system memory or output. When the client inserts the address of the board, the web page will be appear. These web pages will send the HTTP request to the board using GET or POST request method.

Block Diagram And Experimental set up of System:

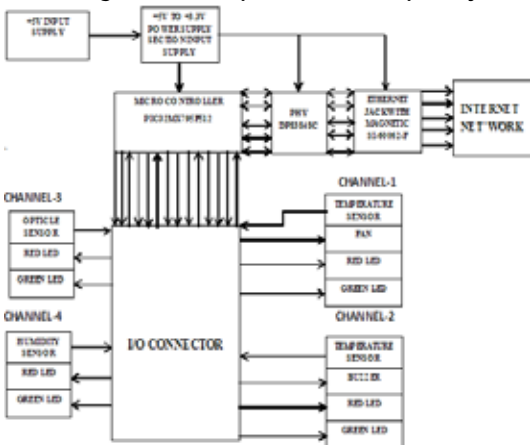

Fig. 4. Block diagram of system

Ref fig.4 This is block diagram Section of Ethernet Project. System has +5V DC input supply section. +5V input go to +3.3V regulator supply section, which generate +3.3V regulated supply for PIC32MX795F512L, DP83848C, Ethernet Jack. There are two sections in microcontroller functioning. Ethernet Section & I/O Section. In Ethernet Section MAC layer of Microcontroller is connected to PHY layer DP83848C and output of DP83848C is connected to Ethernet jack, who has built in magnetics and further it con-

nected to network to get remote access.

In I/O section of PIC32MX795F512L microcontroller is connected to temperature, humidity, optical sensors for input signal and output connected to LED, Hooter, and Fan etc.

Refer fig.5 for Experimental setup of the project.



Fig.5- Experimental Setup

Result

Ref fig. 6, window to monitor and control the industrial Parameter through which particular parameter is monitored and controlled.



Fig.6- WEB Page for monitoring from remote location

The test result for the set up is as below-

7.1. Normal temperature Channel-Channel 1-

- Indicate Required temperature
- Red Led get blow if high condition appears
- Green LED blows in normal operating condition
- Buzzer get ON for high condition

7.2.AdvanceTemperature channel with control application- Channel II-

- Indicate Required temperature
- Red Led get blow if high condition appears
- Green LED blows in normal operating condition
- Fan get ON for high condition and OFF during normal operation

7.3. Humidity Channel, Channel III-

- Indicate required Humidity
- RED LED blow if high condition appears
- GREEN LED blow in normal operating condition

7.4. Optical sensor channel, Channel IV-

- Indicate for availability of obstacle and count from 0-99
- RED LED blow if obstacle available
- GREEN LED blow for non-availability of obstacle

8. CONCLUSION

A low cost approach of the present developed work is novel and has achieved the target to monitor process parameter like temperature, humidity, obstacle remotely using the Ethernet. With the help of the different sensors which can act as a network node using LAN to SPI communication. LAN provides higher data transfer rates and lack of leased telecommunication lines. Workstations can share peripheral devices thus cheaper. Again installation of Ethernet is easier and less expensive than the other network protocols, also provides connectivity to backbone. SPI provides full duplex communication, higher throughput, simple hardware interfacing and typically requires lower power. The system designed in this paper provides the characteristics of low cost and strong processing ability while the electronic unit is simple and reliable.

The system is low cost as compared to the previously existing systems like GSM, Wi-Fi with an accuracy of $\pm 0.1^\circ\text{C}$.

REFERENCE

- [1] PIC32MX5XX/6XX/7XX Family Data Sheet, Microchip Technology Inc., 2008, Doc. no. DS60001156H. Available: <http://ww1.microchip.com/downloads/en/DeviceDoc/61156H.pdf> | [2] LM35 temp sensor data sheet, National semiconductors, document no: DS005516, Available: <http://www.ti.com/lit/ds/symlink/lm35.pdf> | [3] Humidity sensor module SY-HS-220 data sheet, Sensors-ic. Available: <http://web.sensor-ic.com:8000/ZLXIAZAI/apolionion/SY-HS-220.pdf> | [4] Transmissive Optical Sensor with Phototransistor Output data sheet, Vishay Semiconductors, Document Number: 81147 Available: <http://www.vishay.com/docs/81147/tcst2103.pdf> | [5] DP83848C PHYTER Commercial Temperature Single Port 10/100 Mb/s Ethernet Data sheet, National Semiconductor, Literature Number: SNOSATZE | Available: <http://www.ti.com/lit/ds/symlink/dp83848c.pdf> | [6] PIC32MX5XX/6XX/7XX user guide, Microchip Technology Inc., 2008, Doc. no. DS61113C. Available: http://ww1.microchip.com/downloads/en/DeviceDoc/easypic_fusion_v7_manual.pdf | [7] MPLAB® C Compiler For PIC32 MCU User's Guide, Microchip Technology Inc., 2008, Doc. no. DS51686B. Available: <http://ww1.microchip.com/downloads/en/DeviceDoc/51686B.pdf> | [8] The microchip webinar website, [Online]. Available: <http://techtrain.microchip.com/webseminars>. | [9] John Catsoulis "Designing Embedded Hardware", O'Reilly Media, November 20, 2002 chapter 9. | [10] Imran Ahmed, Hong Wong, and VikramKapila, "Internet-Based Remote Control using a Microcontroller and an Embedded Ethernet" Proceeding of the 2004 American Control Conference. | Abstract | Full Text: PDF (413KB) | Full Text: HTML | [11] Application Note AN107, "Practical Thermocouple Temperature Measurements", Dataforth Corporation. | [12] RTD Measurement and Theory www.omega.com/temperature/tz/thertd.html. | [13] N .Mondal, On Certain Topics in Temperature Measurement Using Thermistors, MEE Thesis, Jadavpur University, 1996. Display Temp STOP HTTP handler initialization [HTML file], ADC calculations START If T<=SP T Control device on Initialization of socket, HTTP server, ADC, I/O Port, Ether net Infinite loop Read the Temperature (T) (IJACSA) International Journal of Advanced Computer Science and Applications, Vol. 3, No. 9, 2012 187 | Page | www.ijacsa.thesai.org | [14] BehrouzA.Forouzan TCP/IP protocol suite, vol.3, Basics of protocols. |