



Design And Stress Analysis of Aircraft Wing Rib With Various Cut Outs

KEYWORDS

Stress analysis, aircraft wing rib, cut outs, stress concentration factor

S. Bairavi

PG Scholar, Department of Aerospace Engineering,
Karpagam Academy of Higher Education

Mr. Suresh balaji

Assistant Professor, Department of Aerospace
Engineering, Karpagam Academy of Higher Education

ABSTRACT *Stress concentration in an elastic body may be caused mainly by the two-mechanisms i.e., concentrated forces acting to a body and geometrical discontinuities of a body such as holes or abrupt change of its surface geometry. In this paper the different geometric discontinuities taken into consideration. The local stress increase induced by stress concentration sometimes causes the initiation of a fatigue crack in a structure, which must be carefully examined for engineering design. The presence of cutouts in aircraft wing ribs creates stress concentration, which eventually reduces the mechanical strength of the structure and in extreme cases may lead to its failure. In this paper the induced stresses for ribs with circular, elliptical and rectangular cutouts have been estimated with the help of finite element software package ANSYS 14.*

I. INTRODUCTION

The aircraft is constructed primarily from thin metal skins which are capable of resisting in plane tension and shear loads but buckle under comparatively low values of in-plane compressive loads. For aerodynamic reasons the wing contours in the chord wise direction must be maintained without appreciable distortion. Therefore to hold the skin-stringer wing surface to contour shape internal structural support units are presented which are referred to as wing ribs. Taking into consideration various design and functional aspects, openings are provided in these ribs for access and maintenance of various purposes. In addition to the wing rib main function of maintaining the wing aerodynamic shape, the ribs also are presented for many other purposes that can be

1- Limiting the length of the stringers to an efficient column compressive strength which increases the skin-stringers stability under compressive loads.

2- Transferring and distribution loads

3- Redistributing shear forces at discontinuities in the wing

This rib need to be analyzed for stress values when discontinuities present inside it.

II. PROBLEM DEFINITION

In this paper the passenger aircraft wing rib with different cut outs are and considered for the detailed stress analysis. The wing structure consist number of ribs and box portion of one middle rib having I section is designed for analysis. Stress analysis of the rib with different cut out section is carried out to compute the stresses at ribs due to the applied pressure load.

The main objectives are:

- Computation of stresses of an aircraft wing rib structure due to presence of three types of cutouts such as circle, elliptical and rectangle due to Pressure force over the wing section with the help of ANSYS 14.
- Comparison of stress concentration factor for circle, elliptical and rectangle cut out ribs.

III. LITERATURE REVIEW

Bindu H.C, Muhammad Muhsin Ali.H "Design and Analysis of a Typical wing Rib For Passenger Aircraft" International Journal of Innovative Research in Science, Engineering and Technology. Vol.2, Issue 4,(2013) was found that inserting the circular hole in the plate enhance the buckling strength of the plate. The buckling strength of the plate is increased as the number of holes increased. Mean while the von mises stress in the component keeps on increased as the number of holes increased. Inserting holes in the rib found out to be effective with weight reduction compared to the initial geometry. The maximum stress occurs around the holes and it is to be considered as the critical region in the later stages.

R. Das, R. Jones "Damage tolerance based design optimization of a fuel flow vent hole in an aircraft structure", Journal of Structural Multidisciplinary Optimization, Volume: 38; Pg: 245-265 (2009) demonstrated the application of damage tolerance based optimization to investigate the shape optimization of a Fuel Flow Vent Hole (FFVH) located in the Wing Pivot Fitting of an F-111 aircraft. It is noteworthy that the presence of such 'cutouts' is common in engineering structures used in many industries such as rail, aerospace, naval, and mining. These 'cutouts' are typically used for lightening the structure or for providing passage for equipments and cooling. Hence, the methodologies outlined in this paper to optimize the cutout shape can be easily extended to durability based shape design in similar structures. The shape optimization of the vent hole was performed using the three basic design criteria relevant to damage tolerance design, viz, stress, residual strength, and fatigue life.

K. Kalita, S. Halder, "static analysis of Transversely loaded Isotropic and Orthotropic plates with central cut-out", Journal of Institution of Engineers, India series, C Vol: 95; Issue 4; Pg: 347-358(2014) observed that maximum shear stress in all boundary conditions occurs at the cutout periphery. As expected in all cases, maximum deflection is seen near the cutout and decreases towards the constraints. The variation of SCF for all the plates, in general, is more in orthotropic plate as compared to isotropic

plate. It is observed that SCF depends on elastic constants and hence differ from material to material. The induced stresses in all cases have been intentionally limited within the elastic range by selecting a suitable applied load.

IV. DESIGNING PHASE

The designing is done by modeling software SOLIDWORKS. There are three types of rib structure with different cut outs such as circle, elliptical and rectangle. These three cutouts are designed for stress analysis purpose.

4.1 Designing of Rib structure with Circular holes:

The design length of rib structure is 750mm. It contains seven holes with varying diameters from 28mm to 55mm.

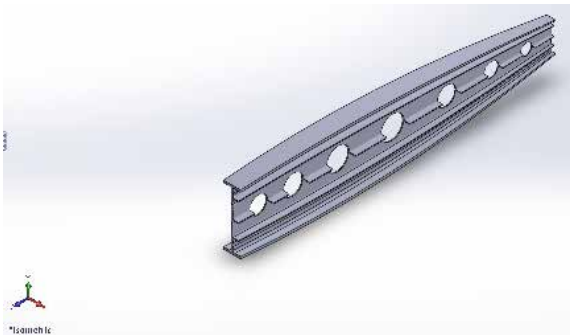

Figure 4.1 Modeling of rib structure with circular holes

4.2 Designing of Rib structure with Elliptical holes:

The design consists of totally seven elliptical holes with varying major diameter of 28 mm to 55 mm and minor diameter varying from 20 mm to 45 mm

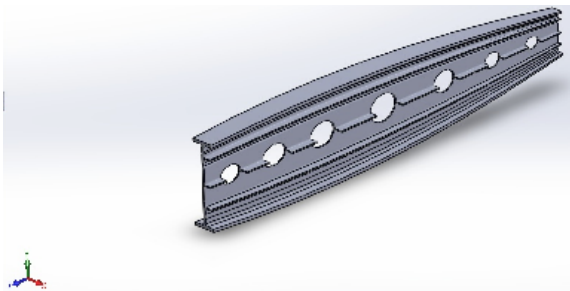

Figure 4.2 Modeling of rib structure with circular holes

4.3 Designing of Rib structure with Rectangular holes

The design consists of seven rectangular holes with varying height from 20mm to 45mm and breadth varying from 28mm to 55mm.

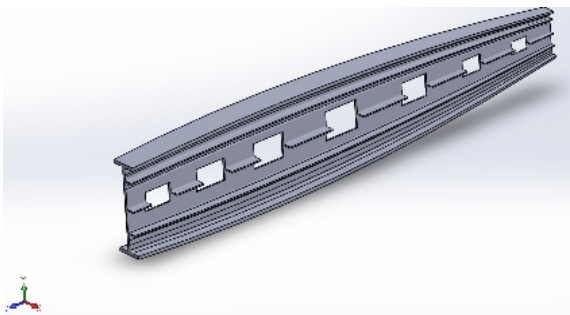

Figure 4.3 Modeling of rib structure with circular holes

V FINITE ELEMENT ANALYSIS

In this project ANSYS 14 software is used as the pre-processor and postprocessor. The pre-processing task includes building the geometric model by importing it from SOLIDWORKS model of rib structure and extracting geometry, building the finite element model, giving these elements the correct material properties, setting the boundary conditions and loading conditions the structure is analyzed. Analysis is done in ANSYS solver phase. It solves the forces and reactions to get stresses. In the post processing stage, the results are evaluated and displayed. The result for all 3 models is tabulated from ANSYS14 software.

5.1 Analysis of rib structure:

AA 2024-T3 is used in current rib structure due to high strength and fatigue resistance properties. The model is imported from SOLIDWORKS to ANSYS 14 to get stress values. After importing the model this has to be meshed, before applying the boundary condition and loading conditions.

TABLE 4.1 MATERIAL PROPERTIES

Density	2770 kg/m ³
Compressive Yield Strength	280 MPa
Tensile Ultimate Strength	310 MPa
Young's Modulus	71000 MPa
Poisson's Ratio	0.33
Bulk Modulus	69608 MPa
Shear Modulus	26692 MPa

5.1.1 Meshing of rib structure with circular holes:

Meshing is the part of analyzing phase. Purpose of meshing is to divide the model into number of individual elements to find the stress distribution. Meshing of circular cut out model is shown in figure below.

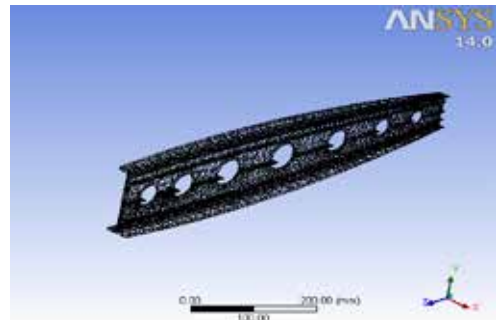

Figure 5.1.1 Meshing contour of rib structure with circular hole

5.1.2 Stress distribution of rib structure with circular holes:

Stress value is high near the cut section. As the load considered at the top portion the maximum stress field occurs in the top portion. The loading values are $\sigma_y = 75 \text{ MPa}$, $\sigma_z = 100 \text{ MPa}$.

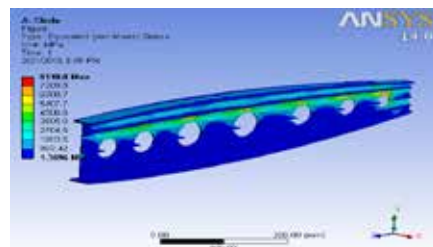

Figure 5.1.2 Stress contour of rib structure with circular holes

5.1.3 Meshing of rib with elliptical holes:

Purpose of meshing is to divide the model into number of individual elements to find the stress distribution. Meshing of elliptical cut out model is shown in figure below.

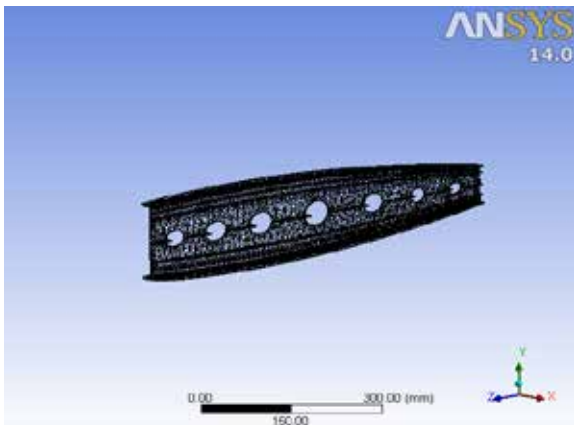

Figure 5.1.3 Meshing contour of rib with elliptical holes

5.1.4 Stress distribution of rib structure with elliptical holes:

Stress value is high near the elliptical cut out section. As the load considered at the top portion the maximum stress field occurs in the top portion. The loading conditions are same for all cut outs.

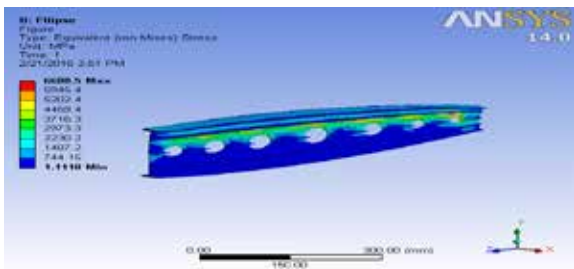

Figure 5.1.4 Stress contour of rib structure with elliptical holes

5.1.5 Meshing of rib structure with rectangular holes:

Purpose of meshing is to divide the model into number of individual elements to find the stress distribution. Meshing of elliptical cut out model is shown in figure 5.1.5.

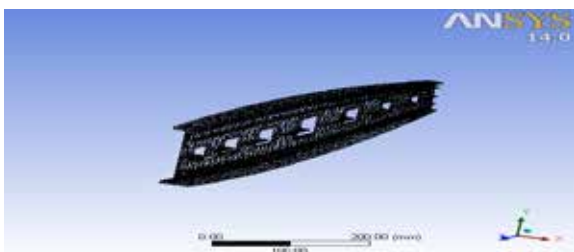

Figure 5.1.5 Meshing contour of rib with Rectangular holes

5.1.6 Stress distribution of rib structure with elliptical holes:

Stress value is high near the cut out section. As the load considered at the top portion the maximum stress field occurs in the top portion. The loading conditions are same for all cut outs.

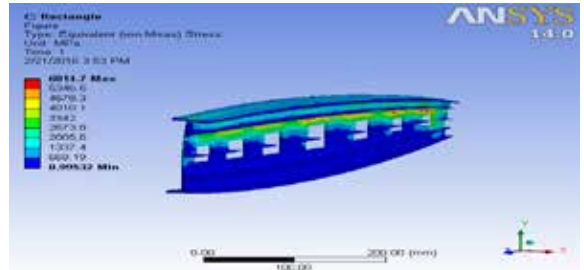

Figure 5.1.6 Stress contour of rib structure with elliptical holes

5.2. Comparison of Stress Results:

The Von mises stress distribution values from the ANSYS output is tabulated below for various cut out sections.

TABLE 5.2.1 STRESS VALUES FOR CUT OUTS

Circular	Elliptical	Rectangle
σ Max	σ Max	σ Max
8110	6600	6014.7
7209	5945.4	5346.5
6308.7	5202.4	4678.3
5407.7	4459.4	4010.1
4506.6	3716.3	3342
3605.6	2973.3	2673.8
2704.5	2230.2	2005.6
1803.5	1487.2	1337.4
902.42	744.15	669.19

5.3. Determination of Stress concentration:

The stress concentration factor for static load can be determined as the relation of the actual maximum real stress in the discontinuity and the average stress, and is obtained through the equation (1).

$$K = \frac{\text{Actual maximum stress}(\sigma_{\max})}{\text{Average stress}(\sigma_{\text{nom}})} \quad \text{----- (1)}$$

K Stress concentration factor

σ_{\max} Actual maximum stress

σ_{nom} Average stress

Stress concentration factor is calculated based on above formula and the values are tabulated for circular, elliptical and rectangle cutouts.

Table 5.2.2 Values of stress concentration factor

Stress concentration factor		
K circular	K elliptical	K rectangular
0.8276	0.6735	0.6138
0.8276	0.6825	0.6138
0.8276	0.6825	0.6137
0.8275	0.6824	0.6136
0.8274	0.6823	0.6136
0.8272	0.6822	0.6134
0.8269	0.6819	0.6132
0.8263	0.6814	0.6128
0.8246	0.6800	0.6115

5.4. Result comparison and conclusion:

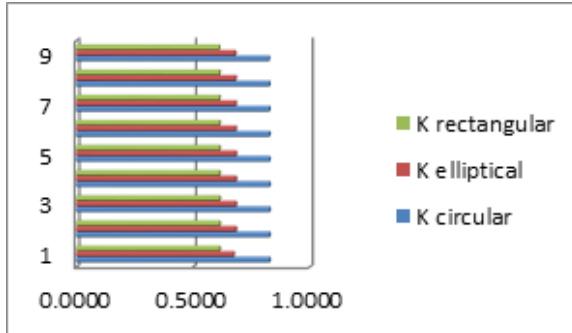

Figure 5.4.1 Comparison of stress concentration factors

- Elliptical holes may lead to high mesh refinement due to its shape.
- Rectangular hole creates accurate corner stresses for simpler bending but the stresses are less accurate for loads.
- Circular hole provides the gradual values of stress. The location of maximum stress concentration factor may vary under different conditions.

VI. REFERENCES

1. Bindu H.C, Muhammad Muhsin Ali.H "Design and Analysis of a Typical wing Rib for Passenger Aircraft" International Journal of Innovative Research in Science, Engineering and Technology. Vol.2, Issue 4, (2013).
2. Darla Sandeep, A. Nageswara Rao "Optimized design and analysis for the development of aircraft droop nose ribs", International Journal of Multidisciplinary Research and Development; Volume: 1; Issue: 7; Pg: 34-41(2014).
3. Zheng Yang *, Chang-Boo Kim, Chongdu Cho, Hyeon Gyu Beom "The concentration of stress and strain in finite thickness elastic plate containing a circular hole", International Journal of Solids and Structures Vol. 45,Pg. 713- 731(2008)
4. K. Kalita, S. Halder, "static analysis of Transversely loaded Isotropic and Orthotropic plates with central cutout", Journal of Institution of Engineers, India series, C Vol: 95; Issue 4; Pg: 347-358(2014).
5. Graeme J. Kennedy, Joaquim R., R.A. Martins "A parallel aero structural optimization framework for aircraft design studies", Journal of Structural Multidisciplinary Optimization, Volume: 50; Pg: 1079-1101(2014).
6. D. V. Kubair "Stress Concentration Factors And Stress-Gradients Due To Circular Holes In Radially Functionally Graded Panels Subjected To Anti-Plane Shear Loading" Journal of Acta Mech, Volume:224; Pg:2845-2862 (2013) Verlag Wien (2013)
7. Quanquan Yang, Cun-FaGao, Wentao Chen "Stress analysis of a functional graded material plate with a circular hole", Journal of Arch Applied Mechanics Springer, Volume: 80; Pg: 895-907 (2010).