



## Computer Aided Ferrous Casting Tooling Design and Cost Analysis

\* Sunil Pipleya \*\* Gunjan Yadav \*\*\* Sumit Chandak

\* Assistant Professor, Department of Mechanical Engineering SVITS, Indore

\*\* Assistant Professor, Department of Mechanical Engineering SVITS, Indore

\*\*\* Assistant Professor, Department of Mechanical Engineering SVITS, Indore

### ABSTRACT

*Casting is a major manufacturing process, which requires an understanding of a wide range of geometrical, material and process parameters. In today's market of intense competition, where the need of the hour is to develop quality products at low cost and short lead time, innovative and cost effective designs are the means to success. Early cost estimation, necessary for design-to-cost philosophy, serves as a decision making tool for the designer when a choice is to be made from a range of alternatives. In casting industry pattern cost estimation is very complex job, because there are not much tools available to estimate the exact pattern cost for the part, and in most of the industries pattern costs are estimated by experience of pattern maker, and this cost may vary from industry to industry and person to person. In addition, experience based cost is suitable only for simple patterns, as pattern complexity increases it becomes more difficult to determine the pattern cost. Through this work, an attempt has been made to cost estimation methodology, which is based on Pro-Engineer and AutoCAST software. This involves parting design and method design to arrive to one of the possible pattern design. Geometrical parameters as volume ratio, thickness ratio, convex surface area ratio, and concave surface area ratio, number of control dimension and quality level are calculated from the pattern design. This is performed on twenty cast part and subsequently regression analysis is done on the data of twenty parts to obtain the equation for pattern cost estimation.*

**Keywords:** Ferrous Casting, Pattern, Core, Tooling Cost, Feeder and Gating Optimization, Regression Analysis.

### 1. Introduction and overview:

Casting is a manufacturing process by which a molten material such as metal or plastic is introduced into a mould, allowed to solidify within the mould, and then ejected or broken out to make a fabricated part. Casting used for making parts of complex shape that would be difficult or uneconomical to make by other methods, such as cutting from solid block of metal (Campbell, 2003). In sand casting, the mould cavity is formed by means of a pattern, which is usually made of wood, plastic and metal, or any other material and has the shape of the part to be cast. The pattern is usually made oversized to allow for shrinkage of the metal as it solidifies and cools. Internal hollow surfaces are determined by means of a core, a sand form placed inside the mould cavity to define the interior hollow geometry of the part. To create the cores a core box needs to be built, which is the negative of the core itself. Different elements of tooling and method include features such as pattern, core box, mould, undercut, parting line, core with its support (or print), pouring basin, sprue, runner, ingate, feeder, feeder connection (or neck) and various feedaids such as chill, insulation and exothermic. Many of these, including pattern, mould, core and core box derived from the part geometry, followed by modification to incorporate various allowances.

With the help of Pro-ENGINEER software, firstly cast parts of different complexities and different sizes are modeled. Then these models were imported in AutoCAST, and their parting line, feeder and gating system were designed. Feeders design is performed so as shrinkage porosity defect free castings can be produced. Then patterns and core boxes were modeled for all the parts. Geometrical parameters like volume ratio, thick-

ness ratio, convex surfaces area ratio, concave surface area ratio etc. which influence the cost of pattern were then calculated. After calculating these parameters average cost of each wood pattern is computed by collecting the estimated cost by different experts. Data sets of geometry parameters and cost are thus generated. Regression analysis is performed on these data sets to get coefficients of the geometry parameters. Thus a general, equation for pattern cost is determined

The tooling cost has two main components - the pattern and the core-boxes. Pattern and core box making requires a high level of skill to achieve the close tolerances and accuracy. This step is critical in the casting process since the castings produced can be no better than the patterns used to make them. The pattern cost primarily controlled by the size of the part (both the envelope and the projected area), number of holes and undercut in part, material for making pattern, required accuracy and finally part complexity. Similarly, cost of the core-boxes depends on their size, material and complexity of core. Much like the pattern, the complexity of the cores will affect the time to manufacture this part of the tooling and hence the cost (Ravi B., 2005).

### 2. Previous works:

A number of cost estimation approaches are available today for estimating part-manufacturing cost at design stage (Camargo and Rabenasolo, 2003). These include intuitive, analogical, analytical, feature based and parametric. The intuitive method based on the experience of the estimator, especially with similar parts and interpretation. The analogical

method involves comparison of a new product with similar existing products. Case based reasoning is applied to improve the results of the analogical method. The analytical method involves decomposition into elementary parts, and empirical equations are used for estimating the cost of various tasks (Feng and Zhang 1999). The feature based method uses geometric features (such as slot, hole and rib) of the product and tooling as the basis for cost estimation (Feng et al. 1996). The parametric cost estimation methods involve formulating relations between product characteristics and its cost using available data. Examples of this approach include cost estimation of injection moulds (Fagade and Kazmer, 2000).

Qing, 2007 used Artificial Neural Network (ANN) technique to estimate the manufacturing cost, ANN are 'model-free estimators' which is a key advantage over traditional approaches such as parametric methods and multiple regression analysis, as with regression analysis, neural networks learn from input-output data samples. Joshi and Ravi, 2010 used regression analysis for estimating the shape complexity of cast part. Their work however did not consider the influence of method design on pattern cost estimation.

### 3. Traditional method design:

The flow of molten metal in the mould and subsequent solidification affect casting quality. This can be controlled by appropriate design of the mould, and method i.e. essentially the cavities corresponding to the casting, gating channels and feeders. Traditional methods of casting design are based on the experience of workers, this means that feeder location and size, as well as gating may not be proper and this may result in defects in casting. After inspecting trial castings, the tooling design is modified until the desired quality and yield achieved. Even then, defects may appear during regular production.

### 4. Computer aided simulation and method design:

Today, a number of casting simulation programs commercially available. In general, Finite Element based programs are more complex to develop and use, but give better results because they can model the casting shape more accurately than finite difference methods. Some of these programs perform coupled simulation of mould filling and solidification, which gives better results. The widespread availability of powerful yet low cost computers has opened the possibility of creating, analyzing and optimizing virtual castings so that real castings can be produced 'right first time and every time'. Computer-aided design and computer-aided manufacturing (CAD/CAM) is now being widely used in general purpose manufacturing, especially for machined parts. In casting domain, software applications are still nascent and expensive, limiting their penetration to mainly large foundries.

### 5. Method design with simulation and example of exhaust bend:

The method layout of a casting is an important aspect of tooling development. It involves decisions regarding part orientation in mould, parting line, cores, cavity layout, feeders, feed-aids and gating system. An improper method layout leads to either poor quality or low yield, affecting manufacturing costs and productivity. Computer simulation provides a clear insight regarding the location and extent of internal defects, ensuring castings are right first time and every time. AutoCAST software integrates and automates the above tasks, and provides an extremely easy to use graphical user interface suitable for even first time computer users. The mould cavities, feeders and gating system are automatically optimized, driven by the criteria and constraints specified by the user. This reduces the total time for method design and optimization of a typical casting to about one hour (AutoCAST software, AR-TECH, 2009).

Part orientation mould and core design: Part Orientation decides the parting surface and parting line, the orientation of part in mould like that it should minimize the complexity of parting line means parting line must be flat because it is easy to manufacturing tooling of cast part having flat parting line.

Also part orientation governs the core complexity and core orientation apart from this part orientation decides the mould size (fig. 5.1).

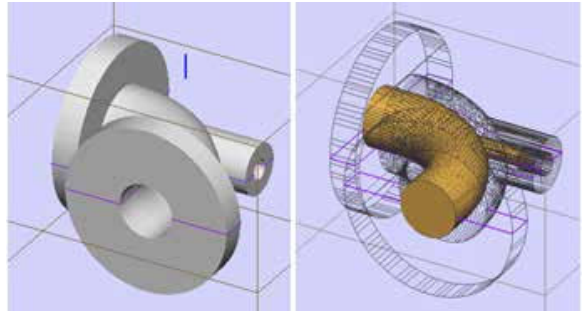

**Figure 5.1: Part orientation mould and core design**

Feeding design: Shrinkage porosity defect can be eliminated by designing the optimal feeder at appropriate location i.e. closest to the part hot spot. By supplying metal to compensate for shrinkage during solidification, the feeder sets up thermal gradients for controlled progressive directional solidification. The parting surface should be chosen so as that the hot spots in the casting facilitate easy access to feeder (fig. 5.2). The effect of various feed-aids such as chills, insulating and exothermic sleeves and covers also help in feeding design. The influence of these feed-aids on solidification can be evaluated by AutoCAST software. The feeders and feed aids can be optimized to ensure porosity free castings while maximizing yield.

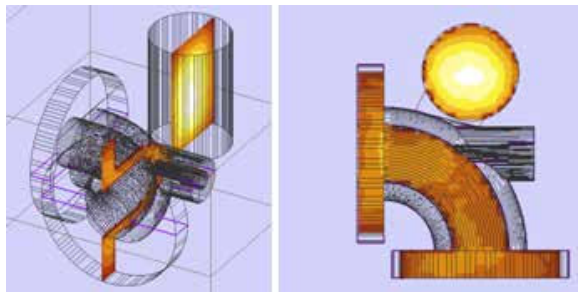

**Figure 5.2: Feeder design and cooling map position**

Gating design: Gating design in AutoCAST, suggests the connection points for ingates and ingates are automatically located on the parting line where free fall height is less.

Design of gating system is done considering, pouring time, casting weight, average section thickness and pouring parameters. Then the dimensions of sprue, runners, and ingates, pouring basin and sprue well are calculated, based on pouring time, choke velocity and gating ratio. As per the requirement, changing of location, number of ingates, runner, and the dimension of gating system elements is possible. After that mould filling simulation is performed to determine the actual filling time, to help in minimizing gating related defects

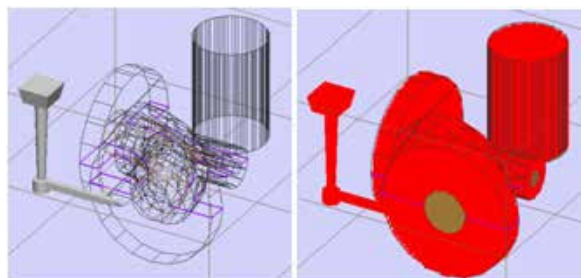

**Figure 5.3: Gating design and mould filling simulation**

Based on such analysis done on twenty parts, parting, feeding, gating design data is obtained. Sample data is presented in the table 5.1.

Table 5.1 Part design, parting design and method design data

PART DESIGN				PARTING DESIGN			FEEDER DESIGN					
Cast Metal	Surface Area (mm <sup>2</sup> )	Volume (mm <sup>3</sup> ) [Bounding box size]	Weight (Kg)	No. of Cores	Under Cut Volume (mm <sup>3</sup> )	Mold Size	No. of Feeders	Feeder Size L/D	Feeder Weight (Kg)	Hot Spot in Feeder	Feeder Yield (%)	
Grey Iron	173874	1505626 [198*198*165]	10.6	1	526111.95	300*300*250	1	133/90	6	Yes	63.9	
GATING DESIGN								POURING PARAMETERS				
No. of Ingates	Gating Weight (Kg)	Gating Yield (%)	Gating Ratio	Choke Area (mm <sup>2</sup> )	Ingate Cross Section	Runner Cross Section	Fill time (secs)	Max. Velocity (m/s)	Pouring Time (sec.)	Pouring Rate (Kg/sec.)	Pouring Temp. (Cel.)	Match Plate Size
1	1.6	96.6	1.96:1.58:1.00	40	8*5	7*9	51.9	1.2	20.3	0.85	1324	300*300



Figure 5.4: Toolings

Table 5.2 Attributes for regression analysis

After that, pattern and core boxes of this part are made, based on data driven by above method design. The tooling's (cope pattern, drag pattern and core boxes) of this part shown in fig. 5.4. Finally, value of attributes of each tooling is obtained and these are presented in the table 5.2. Similarly analysis is performed on all the parts of different complexity and shape

Where:

- V-Volume                      V<sub>b</sub>-Bounding box volume
- A<sub>s</sub>-Surface area              A<sub>convex</sub>-Convex surface area
- T<sub>max</sub>-Max. thickness      A<sub>concave</sub>-Concave surface area
- T<sub>min</sub>-Mini. Thickness      QL-Quality level
- N<sub>cd</sub>-Number of control dimensions

**6. Geometrical attributes for cost estimation:**

Pattern cost is mainly depends on pattern complexity and size. Complexity can be determined by influencing parameters, which directly affect the tooling cost; these parameters are presented in this section.

**Volume Ratio:**

It is the ratio of total volume of cope or drag pattern to its total bounding box volume. Maximum value of volume ratio is one for a solid cube.

**Thickness Ratio:**

The ratio of minimum thickness and maximum thickness for a pattern is known as thickness ratio. These minimum and maximum thicknesses of pattern are considered in all direction for that pattern. Complete pattern on match plate with feeder, core and gating design is considered to calculate minimum and maximum thicknesses according to the design.

**Convex Surface Area Ratio:**

Convex surfaces are those surfaces, which extruded above

the match plate. Most of the patterns consist of convex surfaces more. The ratio of convex surface area to total surface area known as convex surface area ratio.

**Concave Surface Area Ratio:**

Concave surface area ratio is the ratio of concave surface area to total surface area. Concave surfaces are those surfaces, which are below the top face of match plate or below the parting surfaces (example core box). For making this material is to be removed from the solid part.

**Number of Control Dimensions:**

Control dimensions are the dimension which need precision during manufacturing because these dimensions affect part functionality. More the number of control dimensions higher is the machining cost.

**Quality Level:**

Quality directly is related to accuracy, which further depends upon the machine tool condition, use of quality toolings and fixturing. In this paper, three quality levels considered; quality level one, quality level two and quality level three. Quality level one is the highest level of quality, quality level two is moderate level and quality level three is commercial quality level. As the quality level increase tooling cost increases.

**7. Regression analysis:**

On the data of all the parts, which are driven from method design values regression coefficients α<sub>0</sub>, α<sub>1</sub>, α<sub>2</sub>, α<sub>3</sub>, α<sub>4</sub>, α<sub>5</sub>, and α<sub>6</sub> are calculated by Minitab 15 software. Final equation for tooling cost estimation for wood given by equation 7.1.

$$\{ Cost_{tooling} = 1952 - 1717(V/V_b) + 256(T_{min}/T_{max}) - 2750(A_{convex}/A_s) - 2768(A_{concave}/A_s) + 51.3 \times N_{cd} + 20.4 \times QL \dots \dots \dots (7.1) \}$$

Pattern and core box manufacturing procedure varies from part to part and it is not very well documented. Previous cost estimation methods depend on the experience of the tool-maker and may not yield realistic estimates, especially when pattern complexity is high, and no specific method is available especially for pattern cost estimation. Therefore, this equation gives a hybrid model of cost estimation for patterns of sand casting, which based on the geometrical parameters. Further the equation is based on pattern complexity not on the part complexity. This estimation will aid the design engineers and foundry managers to choose the most cost effective design amongst alternatives

**REFERENCES**

1. AR-TECH, Advanced Reasoning Technologies, AutoCAST software, <http://www.autocast.co.in>, 2009. | 2. Camargo, M. and Rabenasolo, B., "Application of the Parametric Cost Estimation in the Textile Supply Chain", *Journal of Textile and Apparel, Technology and Management*, Vol. 3, 2003 pp. 4-12 | 3. Campbell, J., "The New Metallurgy of Metal Castings" Butterworth-Heinemann, Elsevier Science, Burlington, Second Edition (2003). | 4. Fagade, A., Kazmer D., 2000, "Early Cost Estimation of Injection Moulded Components", *Journal of Injection Moulding Technology*, Vol. 4, (2000), pp. 97-106. | 5. Feng, C., Kusiak, A. and Huang, C., Cost evaluation in design with form features. *Computer Aided Des.*, 1996, 28, 875-885. | 6. Feng, S. and Zhang, Y., Conceptual process planning – a definition and functional decomposition. Proceedings of the 1999 ASME International Mechanical Engineering Congress and Exposition, Nashville, TN, Nov. 1999, pp. 97-106. | 7. Joshi D., and Ravi B. "Quantifying Shape Complexity of Cast Parts" *International Journal of Computer Aided Design and Application*, 7(5), (2010), pp. 685-700. | 8. Minitab 15, Statistical Software help, <https://www.minitab.com> | 9. Nagahanumaiah, Ravi B. and Mukherjee, N.P. "An Integrated Framework for Die and Mould Cost Estimation using Design Features and Tooling Parameters", *International Journal Adv. Manufacturing Technology*, Vol. 26, (2005), pp. 1138-1149. | 10. Pro ENGINEER Wildfire 3.0 help, <https://www.ptc.com> | 11. Qing Wing, "Artificial Neural Networks as Cost Engineering Methods in a Collaborative Manufacturing Environment", *International Journal Production Economics*, vol. 109, (2007), pp. 53-64. | 12. Ravi B, "Metal Casting: Computer Aided Design and Analysis", Prentice Hall India, New Delhi, (2005). | 13. Rimasauskas, M. and Bargelis, A. "Framework of Consideration Productivity for Assembling Operations in Sheet Metal Working", *MECHANIKA*, Nr, 5 (55), ISSN pp. 1392-1207 | 14. Wang, H., Zhou, X. H. and Ruan, X.-Y., "Research on Injection Mould Intelligent Cost Estimation System and Key Technologies". *International Journal Adv. Manufacturing Technology* Vol. 3, (2003), pp. 215-222. |