



**ORIGINAL RESEARCH PAPER**

**Information Technology**

**ARTIFICIAL INTELLIGENCE BASED DENSITY BASED SMART TRAFFIC LIGHT**

**KEY WORDS:**

**Divyansh Bagdi** (Class 11<sup>th</sup>) Sarafa Vidya Niketan, Indore.

**CHAPTER-1 INTRODUCTION**

The proposed work is intended to study and analysis the management of traffic light signal. By the use Artificial Intelligence and Arduino technique. Therefore, this chapter provides the basic overview and the core objectives of the presented work.

**1.1 Overview**

Traffic administration has the goal to constantly improve traffic system and regulation. As the number of vehicle users constantly increases and resources provided by current infrastructures are limited, intelligent control of traffic will become a point of focus in the future. Avoiding traffic jams is beneficial to both environment and economy. In our research we focus and optimization of traffic light controller in a city using IR sensor and developed using Arduino. An intelligent transportation system (ITS) estimates the traffic parameters and optimizes traffic signal to reduce vehicle delays and stop. Fixed control on traffic is basically not control according to the density, but in a manner of programming which is already fixed in the system. This thesis proposes an intelligent system using Arduino for implementing it in the city.

**1.2 Motivation**

The traffic lights that are in widespread use today do not do much intricate reasoning when deciding when to change the lights for the various road users waiting in different lanes. How long the signal stays green in one lane and red in another is most often determined by simple timing that is calculated when the crossing is designed. Even though today's methods are robust and work well when the traffic load is distributed evenly across the lanes in the intersection, the systems are very inefficient because they are unable to handle various simple situations that arise throughout the day. Unnecessary waiting time in the signal can be avoided by determining in which side the green signal should be large during the traffic.

**1.3 Objectives**

Traffic management has become one of the severe problems today because of the growth of industrialization and population there has been a tremendous growth in the traffic.

With the increase in traffic there arise a number of problems such as heavy traffic jams, violation of traffic rules etc. Mismanagement and traffic congestion also results in long waiting times, loss of fuel and money etc. It is therefore necessary to have a fast, economical and efficient traffic control system for national development. One way to improve traffic flow and safety of the current transportation system is to apply automation and intelligent control methods to roadside infrastructure as well as vehicles

**Our objective to reduce the following points.**

1. Heavy Traffic Jams.
2. No Traffic, but Still Need to Wait on Signals.
3. Emergency Car /Ambulance Stuck in Traffic Jam.
4. Accident increasing day by day.

**1.4 BACKGROUND**

The background study helps for understanding importance

of the work which have importance to classifying parts of study. This section provides the understanding about the background study of Traffic Signal and there management. Additionally, we also overview of brief introduction of Artificial Intelligence and its technique.

**1.4.1 Artificial Intelligence Overview**

Artificial Intelligence (AI) is a branch of Science which deals with helping machines find solutions to complex problems in a more human-like fashion This generally involves borrowing characteristics from human intelligence, and applying them as algorithms in a computer friendly way. A more or less flexible or efficient approach can be taken depending on the requirements established, which influences how artificial the intelligent behavior appears Artificial Intelligence is a new electronic machine that stores large amount of information and process it at very high speed The computer is interrogated by a human via a teletype It passes if the human cannot tell if there is a computer or human at the other end The ability to solve problems It is the science and engineering of making intelligent machines, especially intelligent computer programs. It is related to the similar task of using computers to understand human intelligence

**1.4.2 Importance of Artificial Intelligence**

Game Playing: We can buy machines that can play master level chess for a few hundred dollars. There is some AI in them, but they play well against people mainly through brute force computation--looking at hundreds of thousands of positions. To beat a world champion by brute force and known reliable heuristics requires being able to look at 200 million positions per second.

Speech Recognition: In the 1990s, computer speech recognition reached a practical level for limited purposes. Thus United Airlines has replaced its keyboard tree for flight information by a system using speech recognition of flight numbers and city names. It is quite convenient. On the other hand, while it is possible to instruct some computers using speech, most users have gone back to the keyboard and the mouse as still more convenient.

Computer Vision: The world is composed of three-dimensional objects, but the inputs to the human eye and computers' TV cameras are two dimensional. Some useful programs can work solely in two dimensions, but full computer vision requires partial three-dimensional information that is not just a set of two-dimensional views. At present there are only limited ways of representing three-dimensional information directly, and they are not as good as what humans evidently use.

Heuristic Classification: One of the most feasible kinds of expert system given the present knowledge of AI is to put some information in one of a fixed set of categories using several sources of information. An example is advising whether to accept a proposed credit card purchase. Information is available about the owner of the credit card, his record of payment and also about the item he is buying and about the establishment from which he is buying it (e.g., about whether there have been previous credit card frauds at this establishment).

**1.4.3 Traffic Management in Artificial Intelligence**

An intelligent transportation system (ITS) is an advanced application which aims to provide innovative services relating to different modes of transport and traffic management and enable users to be better informed and make safer, more coordinated, and 'smarter' use of transport networks.

Some of these technologies include calling for emergency services when an accident occurs, using cameras to enforce traffic laws or signs that mark speed limit changes depending on conditions. Intelligent transport systems vary in technologies applied, from basic management systems such as car navigation; traffic signal control systems; container management systems; variable message signs; automatic number plate recognition or speed cameras to monitor applications, such as security CCTV systems; and to more advanced applications that integrate live data and feedback from a number of other sources, such as parking guidance and information systems; weather information; bridge systems; and the like. Additionally, predictive techniques are being developed to allow advanced modelling and comparison with historical baseline data.

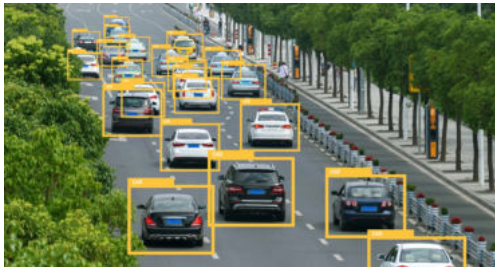

Fig 1.1 Traffic Manage by using A.I

**1.4.4 Application Area of Artificial Intelligence Consumer Marketing**

Have you ever used any kind of credit/ATM/store card while shopping? if so, you have very likely been “input” to an AI algorithm. All of this information is recorded digitally. Companies like Nielsen gather this information weekly and search for patterns – general changes in consumer behavior – tracking responses to new products – identifying customer segments: targeted marketing, e.g., they find out that consumers with sports cars who buy textbooks respond well to offers of new credit cards. Algorithms (“data mining”) search data for patterns based on mathematical theories of learning.

**Identification Technologies:**

ID cards e.g., ATM cards can be a nuisance and security risk: cards can be lost, stolen, passwords forgotten, etc. Biometric Identification, walk up to a locked door – Camera – Fingerprint device – Microphone – Computer uses biometric signature for identification – Face, eyes, fingerprints, voice pattern.

**Machine Translation**

Language problems in international business – e.g., at a meeting of Japanese, Korean, Vietnamese and Swedish investors, no common language – If you are shipping your software manuals to 127 countries, the solution is ; hire translators to translate – would be much cheaper if a machine could do this!

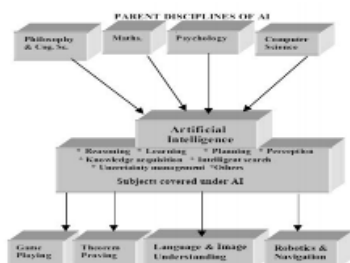

Fig 1.2 Application Area of A.I

**CHAPTER-2 Literature Survey**

This chapter provides the detailed understanding about the traditional traffic management system. In addition of that the key issue in traditional traffic signal management. Moreover, we list the of drawbacks arises in traditional traffic management.

**2.1 Traditional Traffic Light System**

We're going to discuss one of the systems that are being used and implemented in our society, the traffic light system. And as we go on, we're also going to discuss in this thesis the different types of traffic lights that are currently being used today.

**2.1.1 General Overview**

Traffic lights are also named as stoplights, road traffic lamps, traffic signals, stop-and-go lights which are signalling devices placed at road crossings, everyday pedestrian crossings and other locations to control competing flows of traffic. Traffic lights have been fixed all over the world in many cities. Traffic light control assigns a right way to the road users by using lights in normal colours (red – amber/yellow – green). Traffic light control system uses a worldwide colour code (a specific colour order to enable colour recognition for those who are colour blind).

In China, there were unsuccessful efforts to change the importance of “red” to “go” during the Cultural Revolution. Typically traffic lights consist of three types of coloured lights such as red, orange and green. In a typical cycle, turning on of a green light allows traffic to continue in the way indicated. Similarly, lighting of the amber/orange light for a short time of transition represents a signal to prepare to stop, and the Illumination of the red signal disallows any traffic from going on.



Fig 2.1 Traffic Lights

**2.1.2 Traffic Light Controller using Microcontroller**

The main objective of this traffic light controller is to provide sophisticated control and coordination to confirm that traffic moves as smoothly and safely as possible. This project makes use of LED lights for indication purpose and a microcontroller is used for auto changing of signal at specified range of time

interval. LED lights gets automatically turns on and off by making corresponding port pin of the microcontroller "HIGH"

**LED Traffic Lights** – This type of traffic light lamps are using light-emitting diodes as an alternative to the traditional incandescent or halogen light bulbs. LED traffic lights are composed of an array of LED bulbs arranged in diverse patterns, unlike the incandescent-based traffic lights which use a single large bulb. These multiple LED bulbs when viewed from a distance, appears as a continuous light source. Most consumers prefer this type of traffic light because of its numerous advantages such as greater energy efficiency, capability to be solar-powered, much longer lifetime between replacements, bulbs will still operate even if some of the LED bulbs in the array fail, brighter illumination with better contrast against direct sunlight, capability to display multiple colours and patterns from the same lamp, and much faster switching. Instead of sudden burn-out like incandescent-based lights, LEDs start to gradually dim when they wear out which indicates the need for replacement.

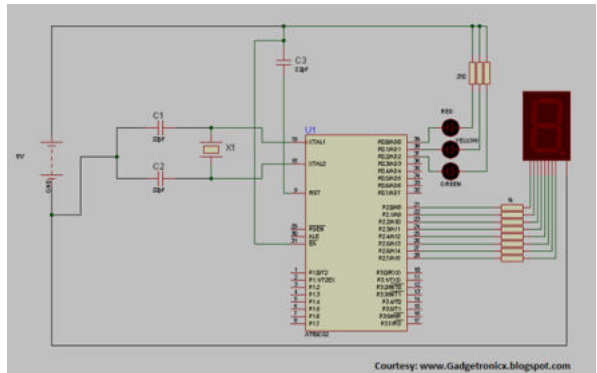

Fig 2.2 Circuit Diagram of Traffic Light Controller

**2.1.3 Working of the Traffic Light Controller**

In the above circuit diagram of traffic light controller, a seven-segment display is used as a counter display, and three LEDs are used for the purpose of traffic light control. An 8051 Microcontroller is the brain of this whole project and is used to initiate the traffic signal at the intersections on road. This circuit diagram makes use of a crystal oscillator for generating frequency clock pulses. The LEDs are interfaced to the Port zero of the microcontroller and are powered with 5v power supply. Seven-segment display is connected to the port2 pins of the 8051 microcontroller with a common anode configuration.

The LEDs get automatically switched on and off by making the corresponding port pins of the microcontroller high, based on the 8051 microcontroller and its programming done by using KEIL software. At a particular period of time, only the green light holds ON and the other lights remains OFF, and after sometime, the changeover traffic light control from green to red takes place by making the succeeding change for glowing of yellow LED. This process continues as a cycle and the timing for changing the LEDs can be displayed with the use of a seven-segment LED display in this project

**2.1.4 Issues in Traditional Traffic Control System.**

The microcontroller-based traffic light system for road intersection control was developed to direct the movement of vehicles meeting at a road junction without any collision. To achieve this, the microcontroller allocates time for each path when the vehicles along that path will move and the other vehicles from the other path will stop. When the time allocated for a specific path has been exhausted, the red light will be ON meaning stop and the next line will be ON (green light) which means the vehicle in that path should start moving. When the time is about to be exhausted, the yellow light will

be ON in the third path informing the vehicles in that path to be ready to move, and after some seconds the green light will be ON. Traffic signals are vital to helping vehicles and pedestrians safely travel. They increase the efficiency and order of traffic to reduce the number of accidents. They provide clear guidelines regarding when cars or pedestrians can enter an intersection or when they should stop and wait. While they are necessary to control traffic and keep commutes as smooth as possible, there are both advantages and disadvantages of traffic signals

**Disadvantage of traffic light are as follows**

1. Timing is fixed.
2. Excessive Traffic Delays
3. Impatient Driving.
4. Cost of Traffic Signals.
5. Emergency Car / Ambulance Stuck in Traffic Jam



Fig 2.3: Traffic Condition in Indore.

In order to reduce signalling time according to density of traffic and give clearance to emergency vehicles the new system which is able to do all these things simultaneously should be established.

**CHAPTER 3 PROPOSED WORK**

This chapter contains the methodology and proposed algorithm for explaining the required system.

**3.1 System Overview**

The proposed operations of Smart Traffic Light Controller. The Infrared Sensors are mounted in the dividers in order to detect the vehicles. The presence or absence of vehicle is sensed by a sensor assembly mounted in the dividers. The Ultrasonic Sensor Will Sense The Number Of Vehicles Standing On the Roads (By transmitting the ULTRAVOILET SOUND which is transmitted by the transmission module and been sensed by the receiver module) will help IR PROXIMITY SENSOR, because PROXIMITY SENSOR can sense the object in some specific length or if any vehicle comes in front of the sensor then the INFRARED rays wont be able to penetrate the vehicle and the exact reading of the TRAFFIC on the roads.

LORA (LONg RANGE Controller), which is been used to make the TRAFFIC SIGNAL more Advanced, it is been used for ADVANCED EMERGENCY MANAGEMENT SYSTEM. Suppose an AMBULANCE is in emergency, then the driver will press the button on which the AMBULANCE is standing .Suppose the driver is present on ROAD 1 then driver will press the button of ROAD 1, then automatically that road will get open i.e. GREEN light will glow.

This section provides the basic details about the proposed system. In next section the detailed system functions are explained.



**3.2 Proposed Model**

The proposed model which is used to implement the traffic vehicle is reported in this section. The model demonstrated in Figure 3.1 and the components of model are explained in the same section.

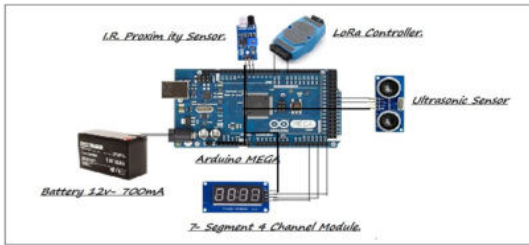

**Fig:3.1 Proposed Model**

**3.3 Component Description**

The various component need to fulfil the requirement of Density based traffic signal

**3.3.1 IR proximity sensor**

Infrared Proximity Sensor is used to calculate number of vehicles standing on the road. The Infrared Transmitter, transmits the IR light and if the object is standing in front of the sensor then the IR light will reflect back and the IR receiver will receive the data and gives the output in the form of I/O (1/0).

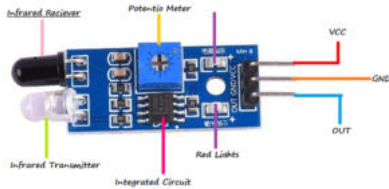

**Fig:3.2 IR proximity sensor**

**3.3.2 Ultrasonic Sensor**

Ultrasonic Sensor is used to calculate the number of vehicles standing on the road, this mechanism is also known as SONAR (used in Ships for NAVIGATION). The ultrasonic Transmitter, transmits the ultrasonic waves and if any object is standing in front of the sensor then the ultrasonic waves comes back after collision with the object and the Ultrasonic receiver module converts the reflected ultrasonic waves to the digital output i.e.I/O (1/0).

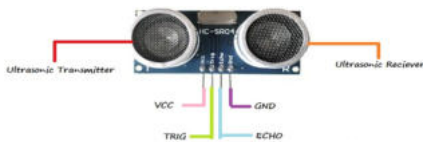

**Fig 3.3 Ultrasonic sensor**

**3.3.3 Wireless Transmitter and Receiver**

Wireless Transmitter and Receiver are used to communicate the project remotely. In the project the use of wireless modules is for emergency purpose. Suppose when Ambulance is in Emergency and it get stuck in heavy Traffic Jam then the Driver can press the button of the road where the ambulance is and the traffic light turns from Red to Green by which all the Emergency vehicle can reach the destination as soon as possible.

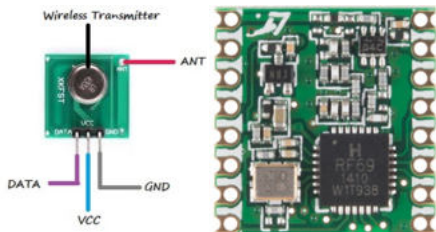

**3.3.4 Arduino Mega**

Arduino refers to an open-source electronics platform or board and the software used to program it. Arduino is designed to make electronics more accessible to artists, designers, hobbyists and anyone interested in creating interactive objects or environments. Also Arduino is used as the mother board and the IC (ATMEGA 2560) is known as the Processor.



**Fig 3.4 Arduino Mega**

**3.3.5 Long Range Controller (LORA)**

Lora Controller is used to make the model wireless with an extreme range of 5KM. Lora is also used for connecting the wireless transmitter and receiver module. In the RX and TX port with Arduino. Lora is designed for long range communication and also specially designed that it takes very low power and high range communication.



**Fig 3.5 LORA**

**3.3.6 LED's**

Three LEDs i.e. Red, yellow and green are used as a traffic light indicator which are connected in series with 1k resistor in the PCB board.

All the LEDs are polarized and all its ground wire is connected together.



**Fig.3.6. Red LED**

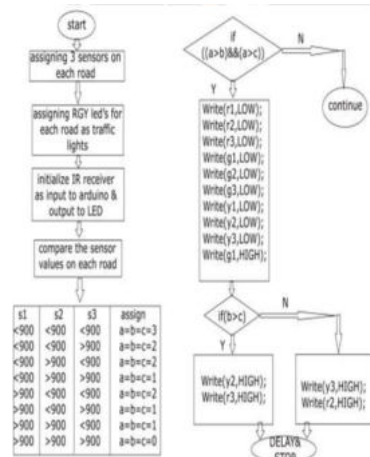

**Fig.3.7. YELLOW LED**



**Fig.3.8. GREEN LED**

**3.4 Flow Chart of our Model**



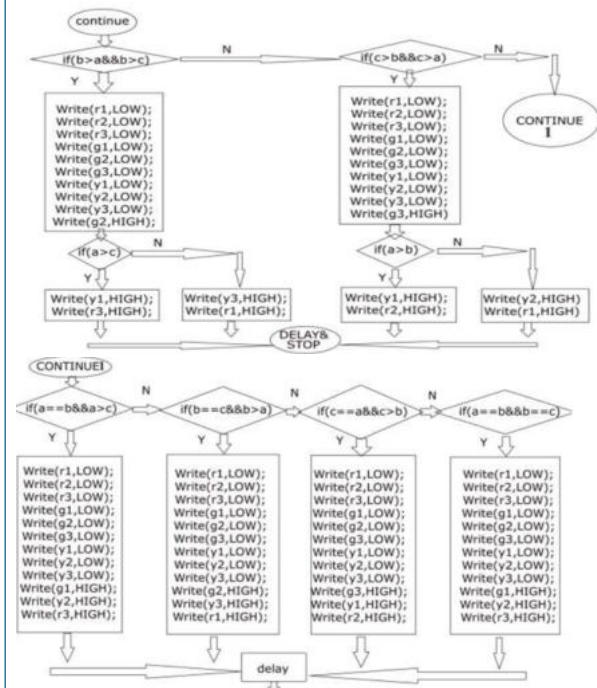

**3.5 Proposed Algorithm**

- Step 1:-** Start
- Step 2:-** Connect A to B cable to ARDUINO and our PC.
- Step 3:-** Open the Arduino.cc and select the board and port.
- Step 4:-** Load the program to ATMEGA2560 micro controller.
- Step 5:-** Connect all VCC ports to 5V and all GND ports to GND.
- Step 6:-** Connect all 12 led's wire according to coding on port 2-13.
- Step 7:-** Connect all 4 timer wire according to coding on port 22-28 (on all even ports).
- Steps 8:-** Place the vehicle on the road according to condition.
- Step 9:-** I.R. sensor and U.S. sensor will sense the traffic and green light time will be changed accordingly.
- Step 10:-** Finish

**CHAPTER-4 Implementation**

The proposed model is used for time management for traffic signal. In this chapter the implementation of the proposed system is described. Therefore the required tools and techniques and implemented scripts are reported in detail.

**4.1 Tools and Techniques**

Implementation of the required system utilizes software and hardware for successfully implementation is listed in this section.

**(A) Technology/Framework- C++**

**(B) Hardware Specifications-**

- 16MHz (clock speed)
- 256KB (8KB by boot loader)
- 8KB (SRAM)
- 4KB (EEPROM)
- 54 Pins (14 provide PWM)
- 16 Pins (Analog input Pins)

**(C) Software Specifications-**

Arduino.cc

**4.1.1 C++ Introduction**

C++ is a middle-level programming language developed by Bjarne Stroustrup starting in 1979 at Bell Labs. C++ runs on a variety of platforms, such as Windows, Mac OS, and the

various versions of UNIX. This C++ tutorial adopts a simple and practical approach to describe the concepts of C++ for beginners to advanced software engineers.

C++ is very close to hardware, so you get a chance to work at a low level which gives you lot of control in terms of memory management, better performance and finally a robust software development.

C++ programming gives you a clear understanding about Object Oriented Programming. You will understand low level implementation of polymorphism when you will implement virtual tables and virtual table pointers, or dynamic type identification.

C++ is one of the every green programming language and loved by millions of software developers. If you are a great C++ programmer then you will never sit without work and more importantly you will get highly paid for your work.

C++ is the most widely used programming languages in application and system programming. So, you can choose your area of interest of software development.

C++ really teaches you the difference between compiler, linker and loader, different data types, storage classes, variable type their scopes etc.

C++ is CUI (Character user interface) language.

**4.1.2 Arduino.cc**

It is a useful C++ component that allows the programmer to give a name to a constant value before the program is compiled. Defined constants in Arduino don't take up any program memory space on the chip. The compiler will replace references to these constants with the defined value at compile time.

This can have some unwanted side effects though, if for example, a constant name that had been const is included in some other constant or variable name. In that case the text would be replaced by the const number (or text).

In general, the const keyword is preferred for defining constants and should be used instead of #define.

**4.2 Code Development**

This section describes the implemented code and their aspects in the simulation therefore the reference classes, implemented code and the methods are described.

**1.2.1 Coding**

```
#include <TM1637Display.h>
const int CLK=22;
const int DI0=24;
const int CLK1=26;
const int DI01=28;
const int CLK2=30;
const int DI02=32;
const int CLK3=34;
const int DI03=36;
int reds1 = 3;
int yellows1 = 4;
int greens1 = 5;
int reds2 = 6;
int yellows2 = 7;
int greens2 = 8;
int reds3 = 9;
int yellows3 = 10;
int greens3 = 11;
int reds4 = 2;
int yellows4 = 12;
int greens4 = 13;
int num=1;
```





```

delay(9000);
digitalWrite (reds4,0);//stopped
digitalWrite (yellows4, 1);
delay (3000);// yellowled lights for 3 sec.
digitalWrite (yellows4,0);
digitalWrite (greens4, 1);
delay (9000);
digitalWrite (greens4,0);// greenled start flashing
delay (500);
digitalWrite (greens4, 1);
delay (500);
digitalWrite (greens4,0);
delay (500);
digitalWrite (greens4, 1);
delay (500);
digitalWrite (greens4,0);
delay (500);
digitalWrite (greens4, 1);
delay (500);
digitalWrite (greens4,0);
delay (500);
digitalWrite (greens4, 1);
delay (500);
digitalWrite (reds1,HIGH);
digitalWrite (reds2,HIGH);
digitalWrite (reds3,HIGH);
digitalWrite (reds4,HIGH);
    
```

**CHAPTER-5 Result Analysis**

The given chapter provides the detailed understanding about the evaluated results of the proposed Density Based Smart Traffic Signal based on Arduino and Artificial Intelligence. Therefore this chapter includes the different performance parameters and their description on which the proposed system is evaluated using different condition.

**5.1 Condition 1 :- When traffic is normal on all roads.**

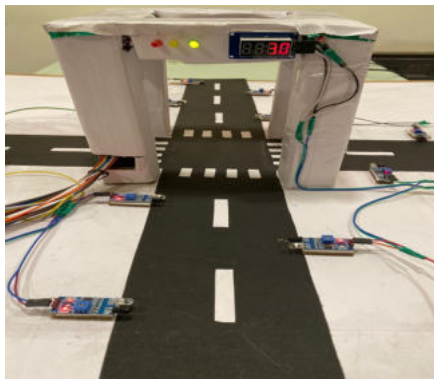

Suppose when traffic is normal i.e. if only and only one – two IR sensor gives reading then the green light will glow normally i.e. like normal traffic light and the timing on the timer would be 30 seconds at most.

**5.2 Condition 2 :- When Traffic is increasing on particular road i.e. (Road A,B,C or D).**

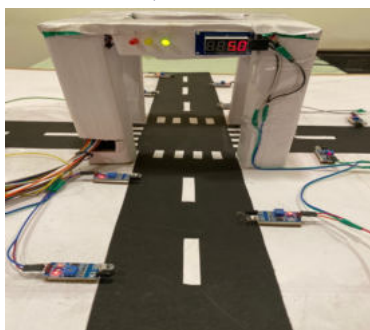

Suppose when traffic is increasing on specific road i.e. On road A,B,C or D, then the green light time will increase according to traffic density on that specific road and if on other road traffic is normal then on other road the green light timing will be 30 seconds at most.

**5.3 Condition 3:- When Traffic density is almost equal i.e. high on all roads.**

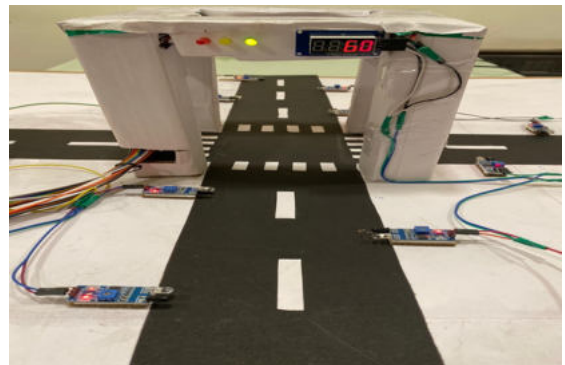

Suppose when traffic is equal or high on all roads then the timing of green light will be increased for all roads. The max. Time for green light in this condition would be 30-50 seconds max at the delay rate of 60-100.

**5.4 Condition 4 :- When any Emergency vehicle standing on road.**

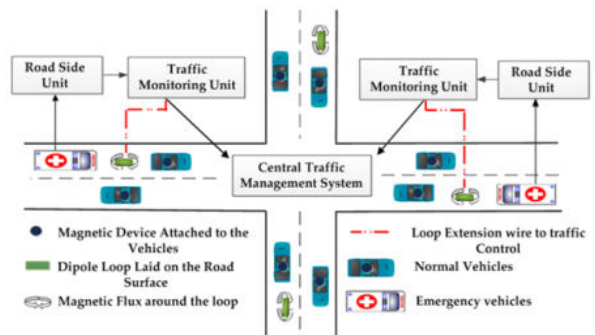

Suppose when an Emergency vehicle (i.e. Ambulance, Police or Fire Brigade) stuck in the traffic jam then the driver of the emergency vehicle can press the button on the road where the vehicle is stuck, by which the traffic light changes from red to green by wireless communication (Transmitter in Emergency Vehicles and Receiver in Traffic Light).

**Chapter 6 Conclusion and Future work**

The main aim of the proposed work is to reduce the congestion problem of the road. In this context a scheme is proposed and implemented successfully. This chapter contains the conclusion of the made effort based on the experiments and observations.

**6.1 Conclusion**

The Design and Implementation of the DENSITY BASED SMART TRAFFIC LIGHT BASED ON ARTIFICIAL INTELLIGENCE is to Save time (because “TIME IS MONEY”) to decrease Man Power, and Increased in Development of Artificial Intelligence and Making our city Smart and Decrease Rush on Roads. The main feature of our model is automation on roads and also wireless technology for any emergency vehicles to reach the destination as soon as possible.

In this design work, a density based traffic light control system was developed for traffic control at '+' road intersection to reduce unnecessary time wastage and minimize road traffic casualties which the existing conventional traffic light control system has failed to achieve. As demonstrated by the test

results in the simulation and the prototype implementation as shown in Figure 10 (a-e), the design has shown that the system developed is a viable tool for traffic control and the incorporation of a surveillance system would help reduce road casualties caused by road users who ignore traffic signals. Lastly, the objectives of the design were achieved. This thesis has presented a means of controlling traffic at '+' road intersection using infrared sensors with an embedded microcontroller chip. Specifically, it demonstrates a working software solution for controlling traffic based on the density of traffic on each lane at the intersection. It provides a means of succour away from the conventional traffic light associated with even timing of lanes of traffic irrespective of the number of vehicles on the lanes per kilometre which is the density associated with that lane. This project as resourceful as it has proven to be can be improved upon by; the incorporation of renewable energy sources for 24 hours performance of the system. The system could also be designed to transmit captured vehicle plate numbers of defaulters in real time to relevant traffic agencies. Lastly, the design can be modified to control more than four lanes of traffic.

## 6.2 Future Work

The key objective of the proposed work is to reduce the congestion problem on the road. Therefore, a new model is implemented and designed. That mode is efficient and accurate and can be used for various tasks. Based on the utility of the proposed Artificial Intelligence technique the following future of the work is proposed:-

1. This project may spearhead the revolution of Digital India and Smart City.
2. Building a smart city with automatic traffic transmission is possible as emergency vehicles can communicate with the traffic system wirelessly and take decisions on their own, making autopilot more of a reality.
3. This project may replace current traffic system and open up more avenues for a future ready world.

## References

- [1.] Neil Sahota and Michael Ashley "Own the A.I revolution".
- [2.] Brigitte Tasha Hyacinth The Future of Leadership Rise of Automation, Robotics and Artificial Intelligence. Leadership
- [3.] Prof. R.U. Yawle#1, Kiran.K.Modak#2, Parmeshwar.S.Shivshette#3, Snehal.S.Vhav Smart Traffic Control System
- [4] Wikipedia and Britania.com
- [5] Pramod Sharma "Density Based Intelligent Traffic Control System Using IR Sensors" Intl journal of scientific Research.
- [6] R. WEIL, J. WOOTTON AND A. GARCIA-ORTIZ " Traffic Incident Detection Sensor and Algorithms" Mathl.Comput.Modeling Vol.27.

## Websites:

- <https://www.arduino.cc/en/Main/ArduinoBoardMega>
- <http://www.instruconnect.net/arduino>
- <http://www.udemy.com/beginning-arduino>
- <http://www.quora.com/building-first-arduino-circuit>
- <http://en.wikipedia.org/wiki/arduino>